



LACROSSE

2012 AND 2013 RULES
AND INTERPRETATIONS



RESPECT.

It's the name of the game.

Sportsmanship is a core value of the NCAA. The NCAA Committee on Sportsmanship and Ethical Conduct has identified **respect** and **integrity** as two critical elements of sportsmanship and launched an awareness and action campaign at the NCAA Convention in January 2009.

Athletics administrators may download materials and view best practices at the website below: **www.NCAA.org**, then click on **"Student-Athlete Programs,"** then **"Sportsmanship"** and select the **"Resources/Best Practices"** tab.



2012 and 2013 NCAA WOMEN'S LACROSSE RULES AND INTERPRETATIONS

NATIONAL COLLEGIATE ATHLETIC ASSOCIATION



[ISSN 0735-9195]
THE NATIONAL COLLEGIATE ATHLETIC ASSOCIATION
P.O. BOX 6222
INDIANAPOLIS, INDIANA 46206-6222
317/917-6222
WWW.NCAA.ORG
NOVEMBER 2011

Manuscript Prepared By: Pat Dillon, *Secretary-Rules Editor, NCAA Women's Lacrosse Rules Committee.*
Edited By: Rachel Seewald, *Associate Director for Playing Rules Administration.*

NCAA, NCAA logo and NATIONAL COLLEGIATE ATHLETIC ASSOCIATION are registered marks of the Association and use in any manner is prohibited unless prior approval is obtained from the Association.

COPYRIGHT, 2006, 2007, 2008, 2009, 2011 BY THE NATIONAL COLLEGIATE ATHLETIC ASSOCIATION
PRINTED IN THE UNITED STATES OF AMERICA

Contents

NCAA Women’s Lacrosse Rules Committee.....	4
Major Rules Changes for 2012 and 2013.....	6
New Officiating Procedures.....	7
Points of Emphasis.....	8
Official NCAA Women’s Lacrosse Rules	
Rule 1—The Playing Area and Goals.....	9
Rule 2—Equipment and Uniforms.....	15
Rule 3—Game Personnel.....	19
Rule 4—Time Factors and Scoring.....	23
Rule 5—Play of the Game.....	26
Rule 6—Fouls.....	36
Rule 7—Penalty Administration.....	42
Rule 8—Definition of Terms.....	50
Appendix A: Pregame Protocol.....	55
Appendix B: Umpire Signals.....	56
Appendix C: Lightning Policy.....	60
Appendix D: Blood Guidelines.....	61
Appendix E: US Lacrosse Manufacturer’s Specification for Equipment.....	62
Appendix F: Measurement Conversions.....	74
Appendix G: Alternate Official Responsibilities and Duties.....	75
Appendix H: Concussions.....	77
Index to Rules.....	79

US Lacrosse Acknowledgement

The NCAA acknowledges US Lacrosse, the national governing body of men’s and women’s lacrosse, and the former United States Women’s Lacrosse Association for their respective roles in developing and publishing the rules of women’s lacrosse since 1932. The NCAA rules book was developed based on current US Lacrosse Official Rules for Girls’ and Women’s Lacrosse, and the NCAA continues to work collaboratively with US Lacrosse in the area of rule development.



NCAA Women's Lacrosse Rules Committee



Chair
Celine Cunningham
Division III
Stevens Institute of
Technology
201/216-8056
celine.cunningham@
stevens.edu
Term expires: 9-1-14



**Secretary-Rules
Editor**
Pat Dillon
Beltsville, Maryland
301/656-6522
pdillon656@aol.com
Term expires: 9-1-14



**Gail Cummings-
Danson**
Division III
Skidmore College
518/580-5370
gcumming@
skidmore.edu
Term expires: 9-1-12



Missy Doherty
Division I
Penn State University
814/863-7476
mhd14@psu.edu
Term expires: 9-1-12



Paula Habel
Division III
Bridgewater State
University
508/531-2898
P.Habel@gmail.com
Term expires: 9-1-15



Rachelle Held
Division I
Canisius College
716/888-2877
heldr@canisius.edu
Term expires: 9-1-15



Keely McDonald
Division I
Brown University
401/863-9378
Keely_mcdonald@
brown.edu
Term expires: 9-1-13



Amanda O'Leary
Division I
University of Florida
352/375-4683
amandao@gators.ufl.edu
Term expires: 9-1-14

Major Rules Changes for 2012 and 2013

The figures below refer to rule, section and page, respectively. Each changed or altered segment is identified in the rules by a shaded background.

<i>Rule(s)</i>	<i>Explanation</i>	<i>Page</i>
1-10	Added a specific penalty area at the rear of the substitution area.....	10
3-2	Head coaches and officials will meet together pregame at a specified location and time.....	19
3-9-c	Both teams allowed to be present for any communication with the officials.....	20
5-1	Maximum of three players from each team allowed between the restraining lines during the draw.....	26
5-2	On the draw, the ball must be placed in the upper third of each head at its widest point.....	27
6-7	Offside will now be determined by counting players for each team who are behind the restraining line.....	40
7-6	Free position set up for offside foul by the attack will change.....	43
7-10	Free position set up for goal circle foul by the defense will change..	44
7-28	Player receiving a yellow card will serve a two-minute releasable penalty; team to play short below each restraining line.....	47
7-30	Player receiving a red card will serve a two-minute non-releasable penalty; team to play short below each restraining line.....	48
7-31	Any player serving penalty time who enters early will serve an additional two-minute penalty.....	48
7-32, 33	Head coach will be carded for lack of bench decorum by anyone in the team bench area; head coach will designate a player to be removed from the field to serve the penalty.....	48
8-Definitions	Added definition for releasable and nonreleasable penalties and penalty area; adjusted definition for played.....	52

New Officiating Procedures

1. On the set up for the draw the official will now place the ball in such a way that it sits between the sticks in the upper third of each head at its widest point.

2. The free position for offside fouls by the attack will now be taken at the spot of the ball. The closest defender to the spot will take the free position, the attack player with the ball will go 4m behind, and the attack player closest to the restraining line will be moved back outside.

3. The free position setup for goal circle fouls by the defense will change and will no longer be considered a minor foul (indirect). The player with the ball will be 8m from goal along the goal line extended; the offending player will be placed 4m behind.

4. Additional officiating signals are currently being developed. A full listing of signals with illustrations is available on both the NCAA and US Lacrosse websites.

Points of Emphasis

The “Points of Emphasis” section highlights certain areas of the game the Women’s Lacrosse Rules Committee believes warrant continued attention by placing a stronger emphasis on existing rules.

The committee requests that players, officials and coaches concentrate on the following areas:

Dangerous Propelling

A basic tenet of women’s lacrosse has always been that it is the attack player’s responsibility to shoot safely. A shot taken without regard to the positioning of other players, whether they are in the free space to goal legally or illegally, should be penalized with a yellow card for dangerous propelling. The ball does not actually have to hit the player for this call to be made and a card given.

Fouls after the Shot

The committee is becoming increasingly concerned with the number of fouls occurring after a shot has been released. The defender who makes no attempt to play the ball, but forcefully hits, shoves or pushes the attack player after the shot must be carded. Officials should also consider carding the defender who is attempting to play the ball, but is not in control while doing so, in this situation. The attack player also has the responsibility to be playing under control. If they cause the contact by crashing through a defender who has established position, any goal scored must be called back and the attack player penalized for charging after the shot.

8M Free Position Set Ups

Once the whistle has blown to stop play and an 8m free position is being set up, players should not be moving or repositioning to gain an advantage when clearing the arc. While the lead official has primary responsibility in the 8m arc, all three officials must be involved in this important free position set up. All three officials must insist that players stand until they are directed to move, and the trail officials must step in and assist the lead official in controlling player movement.

RULE 1

The Playing Area and Goals

The Playing Area

Field Dimensions

SECTION 1. The playing area shall be rectangular and marked with a solid lined boundary. The field should be between 101m and 128m (110 to 140 yds.) from end line to end line; and between 55m and 64m (60 to 70 yds.) from sideline to sideline. The goals shall be placed not more than 92m (100 yds.) and not less than 82m (90 yds.) apart, measured from goal line to goal line. There must be 9m (10 yds.) of space behind each goal line, extending to the end line and running the width of the field. There must be a minimum of 4m (4.4 yds.) of space between the sideline boundary and the scorer's table. There should be at least 4m of space between the other sideline and any spectator area. There should be 2m (6'6") of space beyond each end line.

SECTION 2. It shall be the host institution's responsibility to see that the field is in proper condition for safe play, and that the field is consistent with the rules. Where optimal field dimensions as listed in Rule 1-3 are not or cannot be met due to field-space limitations, play may take place if the visiting team has been notified in writing before the day of the game and personnel from both participating teams agree. Soft/flexible cones, pylons or flags must be used to mark the corners of the field. The playing area must be flat and free of glass, stones and any protruding objects. No additional marks may be added to the field.

New Field Construction

SECTION 3. Optimal field dimensions shall be 65 yards in width and 120 yards in total length, with goals 100 yards apart and 10 yards of space behind each goal line. Additional space outside the playing area is required. See Rule 1-1.

Line Size and Color

SECTION 4. All lines are 5cm-10.1cm (2"-4") wide, except the goal line, which shall be 5cm (2") wide. It is recommended that all lines be painted white or a single contrasting color.

Restraining Line

SECTION 5. The restraining line, a solid line 27m (30 yds.) up field from each goal line, shall extend across the width of the field. It must be clearly distinguishable as the restraining line, for example, the only line on the field, or marked in a different color, or marked with X's. Cones shall not be used for this purpose.

Center Circle

SECTION 6. There is a circle, with a radius of 9m (30'), in the center of the field and through the center of this a line 3m (9'11") in length, parallel to the goal lines.

Arc and Fan

SECTION 7. An arc and fan shall be marked 8m (26'4") and 12m (39'4"), respectively, from the goal circles. The arc and fan shall be measured from the center of the goal line 10.6m (34'10") for the 8-meter mark and 14.6m (47'9") for the 12-meter mark. The 8-meter arc shall end on a line on each side that runs from a point on each side of the goal circle, where, if the goal line were continued, would cross the goal line. This line will be at a 45-degree angle to the goal line extended. The 12-meter fan will end at the goal line extended.

SECTION 8. The 8-meter arc will be sectioned off by hash marks 30.5cm (1') in length, perpendicular and bisecting the arc. These will be measured 4, 8 and 12 meters, respectively, from either side of the center hash mark, which shall be measured from the center of and perpendicular to the center of the goal line (10.6m/34'10"). Two additional 30.5cm (1') marks will be made 8 meters from the goal circle, perpendicular to the goal line extended.

Substitution Area

SECTION 9. The substitution area shall be in front of the scorer's table and centered at the midfield line. The area will be sectioned off by two hash marks, 2m-4m in length. The hash marks will be placed perpendicular to and touching the sideline with each one placed 4.5m (5 yds.) from the center line of the field.

Penalty Area

SECTION 10. The penalty area shall be directly in front of the scorer's/timer's table at the rear of the substitution area. A player serving a penalty must sit or kneel in this area.

Team Bench Area

SECTION 11. The team bench area is defined as the area from the end of the substitution area to the team's restraining line, and behind the level of the scorer's table extended. Non-playing team personnel must remain in their team bench area. Violation of this rule will be assessed as a misconduct foul.

Scorer's/Timer's Table

SECTION 12. A scorer's/timer's table will be set up at midfield, at least 4m (4.4 yds.) from the designated playing boundaries on the teams' bench side. An accurate visible score must be continuously displayed. A visible clock is recommended.

Coaching Area

SECTION 13. Coaches must remain within their own coaching area, that is, the area on the bench/table side of the field extending from their side of the substitution area to their end line, and up to the sideline. Violation of this rule is misconduct.

A.R. 1-1. An assistant coach is on the opposite side of the field from the scorer's table coaching his/her team. **RULING:** ILLEGAL. A coach may move along the bench/table side boundary line from the substitution area to his/her end line only. Violation is considered misconduct.

Spectator Areas

SECTION 14. Spectators must be kept back at least 4m (4.4 yds.) from the sidelines. Spectators are not allowed immediately behind the team bench or table area, except in permanent stadium seating. No spectators are allowed behind the end lines, except in permanent stadium seating positioned behind protective netting or fencing.

Directions for 8-Meter Arc/12-Meter Fan

8-METER ARC (See Diagram 1)

1. The two sidelines are made first. Run string from the point (A) on the back of the goal circle that is perpendicular to the goal line at its center, to the points on the goal circle (B), where if the goal line were extended would intersect the circle. Extend and mark these lines (45-degree angle) from the goal circle (B) 8.58m (28' 3") to point C.
2. To mark the curve of the arc, measure from the center of the goal line (D) 10.6m (34' 10") to G connecting the sidelines. The arc will now be 8 meters from the circle.
3. The center hash mark 30.5cm (1') on the 8-meter arc shall be measured from the center of and perpendicular to the goal line (10.6m/34' 10"). The other hash marks will be measured 4, 8 and 12 meters, respectively, from either side of the center hash mark. Two additional hash marks will be made 8 meters from the goal circle, perpendicular to the goal line extended.

12-METER FAN (See Diagram 1)

Inscribe a semicircle (E) from the center of the goal line (D) 14.6m (47' 9"). The flat side of the semicircle should be marked from the points on the goal circle (B) to the semicircle.

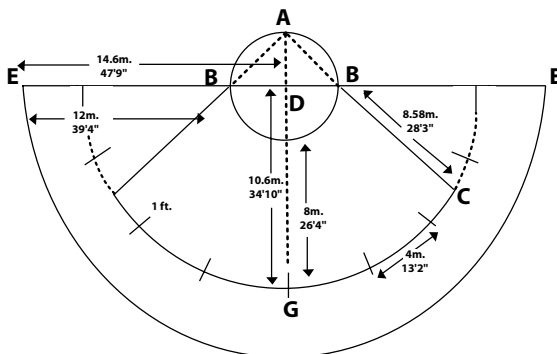

Diagram 1 - 8m arc/12m fan

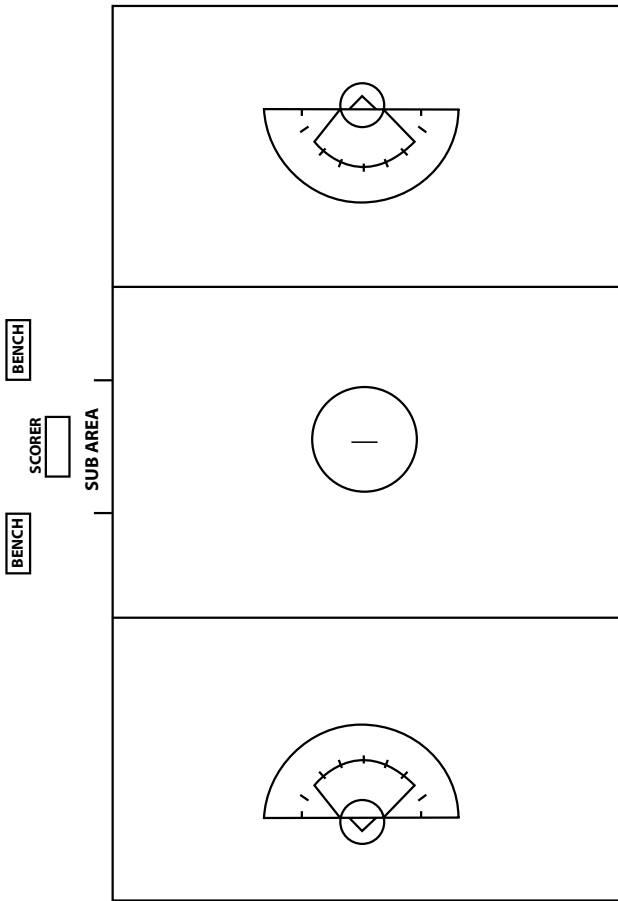

Diagram 2 - Field Set Up
(Not Drawn to Scale)

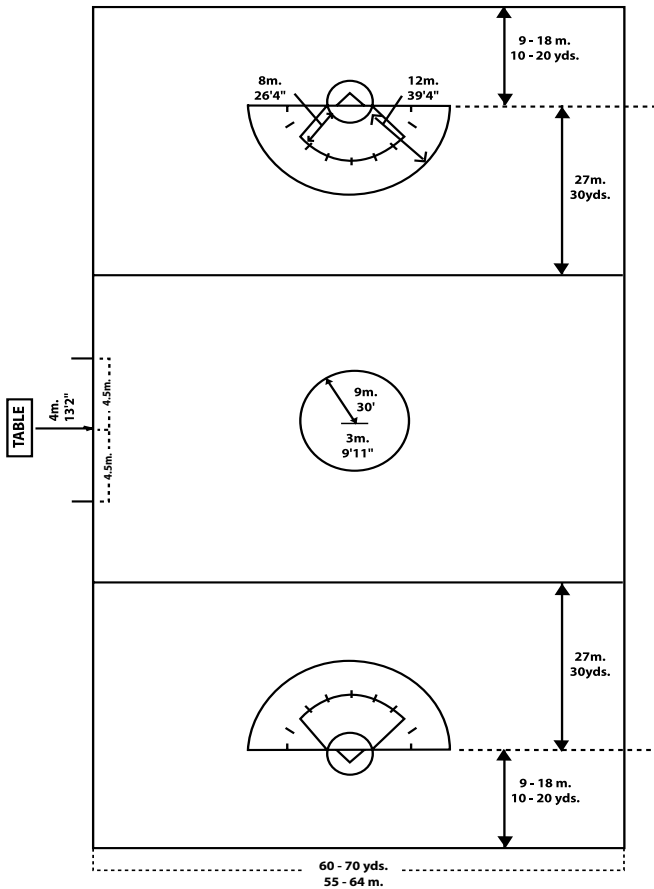

Diagram 3 - Measurements
(Not Drawn to Scale)

The Goals

The Goals

SECTION 15. Each goal consists of two posts or pipes perpendicular to the ground, constructed of metal, 1.83m (6') high and 1.83m (6') apart, joined at the top by a cross-bar 1.83m (6') from the ground (inside measurements). The goal posts (pipes) must not extend upward beyond the cross-bar nor the cross-bar sideways beyond the goal posts. The posts and cross-bar must be a solid white, orange or silver color and be 4 to 5cm (1.5 to 2") in diameter. A line called the goal line must be drawn between the two posts, continuous with them and of the

same width. The netting, not more than 4cm (1.5") mesh, must be attached to the posts and cross-bar and to a point on the ground 2.1m (7') behind the center of the goal line; it must be firmly pegged down. Whenever possible, the net should be strung so as to prevent the rebounding of the ball. Any additional goal supports that are exposed must be padded the entire length with material that limits the rebound of the ball. Goal cages that have "flat" supports or angled ground pipes that prevent the ball from re-entering the playing area after hitting the ground pipe, do not have to be padded.

Goal Circle

SECTION 16. The goal circle is a circle, with a radius of 2.6m (8'6") measured from the center of the goal line to the outer edge of the goal circle line. The goal circle line shall be 5cm-10.1cm (2"-4") wide.

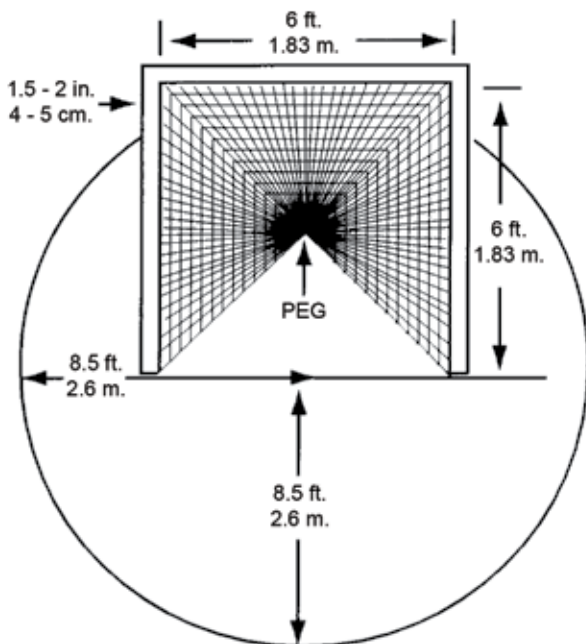

Diagram 4 - The Goal

RULE 2

Equipment and Uniforms

Equipment

Field Crosse

SECTION 1. The field crosse must be made of the following basic materials: composite, metal alloy (handle only), rubber, wood, gut, leather, fiberglass, nylon, plastic or any other synthetic material. (Recessed metal screws may be used to affix the head to the handle.)

The head of the stick shall be triangular in concept and shall be affixed to the handle in such a way that it shall basically be in the same plane as the handle.

The pocket of the stick shall be strung with four or five longitudinal leather and/or synthetic thongs, eight to 12 stitches of cross-lacing and not more than two “shooting/throw” strings. Mesh pockets are not allowed.

The crosse shall not have sharp or protruding parts or edges, and shall not be dangerous to players in any way.

The crosse’s overall length shall be a minimum of .9m (35-1/2”) and a maximum of 1.1 m (43-1/4”).

SECTION 2. A crosse meets specifications if:

- a. It complies with the criteria in this rule and it meets the Manufacturer’s Specifications as approved by US Lacrosse and listed in Appendix E.
- b. The top of the ball remains above the top of the wooden or plastic wall after pressure has been applied to and released from a ball dropped into the pocket of a horizontally held crosse.
- c. The ball moves freely within all parts of the head of the stick, both laterally and along its full length.

A.R. 2-1. A player has woven the thongs of the crosse back up through the head of her crosse.

RULING: ILLEGAL. A crosse may have only four or five thongs. Weaving the existing thongs through the head essentially adds extra thongs. Umpires should watch for this during pregame stick check.

A.R. 2-2. During the pregame stick check, it is discovered that a field player is using flat shoelaces as her shooting/throw strings. **RULING:** ILLEGAL. The player may not use this crosse until the shoelaces have been removed. If the shoelaces are discovered on a crosse in play, it will be removed from the game and penalized as a minor foul.

Goalkeeper Crosse

SECTION 3. The goalkeeper crosse must be made of the following basic materials: composite, metal alloy (handle only), rubber, wood, gut, leather,

fiberglass, nylon, plastic or any other synthetic material. (Recessed metal screws may be used to affix the head to the handle.)

The head of the stick shall be triangular in concept and shall be affixed to the handle in such a way that it shall basically be in the same plane as the handle.

The pocket of the stick shall be strung with six or seven longitudinal leather and/or synthetic thongs and crosse lacing, or be mesh.

The crosse shall not have sharp or protruding parts or edges, and shall not be dangerous, to players in any way.

The crosse's overall length shall be a minimum of .9m (35-1/2") and a maximum of 1.22m (48").

SECTION 4. A crosse meets specifications if:

- a. It complies with the criteria in this rule and it meets the Manufacturer's Specifications as approved by US Lacrosse and listed in Appendix E.
- b. The ball moves freely within all parts of the head of the crosse, both laterally and along its full length.

A.R. 2-3. The blue goalkeeper is using three shoelaces as her shooting/throw strings, with two across the top of the stick and one forming a "V" down the middle. **RULING:** LEGAL. The goalkeeper crosse may have more than two shooting/throw strings and may use shoelaces as those strings. With the mesh pocket, the goalkeeper crosse may contain some stringing other than at the top of the crosse.

A.R. 2-4. The goalkeeper who is outside the goal circle switches crosses with a field player. **RULING:** ILLEGAL. The field player is penalized for having a crosse that does not meet specifications.

The Ball

SECTION 5. The ball is smooth or slightly textured rubber of solid yellow or bright orange (similar to Pantone #811) color, not less than 20cm (7-3/4") nor more than 20.3cm (8") in circumference. It must weigh not less than 142gm (5oz.) nor more than 149gm (5-1/4oz.). It must have a bounce of not less than 1.1m (43") nor more than 1.3m (51") when dropped from 1.8m (72") onto concrete at a temperature of approximately 18 C (65 F) to 23 C (75 F).

The teams must agree on which type (smooth or textured) and color (yellow or bright orange) ball to use prior to game time. If no agreement can be reached, the default will be a smooth yellow ball. For all NCAA tournament games, the smooth yellow ball will be used.

Goalkeeper Equipment

SECTION 6. The goalkeeper must wear a helmet with face mask, a separate throat protector, padded gloves, a mouthpiece, and a chest protector. The protective helmet, designed for lacrosse, must meet the NOCSAE test standard and must have a chin strap securely attached.

SECTION 7. It is recommended that the goalkeeper wear padding on arms, legs and shoulders. This padding must not excessively increase the size of these body parts. Body padding must not exceed the thickness of legal goalkeeping gloves – 2.54cm (1") padding. Gloves must not contain any webbing and must not excessively increase the size of the hands as they are presented to the ball.

A.R. 2-5. A goalkeeper wears football shoulder pads. **RULING:** LEGAL, if they do not exceed the maximum legal thickness of 1".

A.R. 2-6. A goalkeeper wears canvas field hockey leg pads. **RULING:** LEGAL, if they are pulled tight or taped around the leg. Bamboo/cane field hockey pads are illegal.

A.R. 2-7. A goalkeeper wears a throat protector that is attached to her helmet using screws. **RULING:** LEGAL. This is one type of “separate” throat protector.

Mouthpiece

SECTION 8. All players must properly wear a professionally manufactured intra-oral mouthpiece that fully covers the upper jaw teeth. The mouthpiece must not be altered to decrease protection, and there may be no protruding tabs for field players. It is recommended that the mouthpiece be properly fitted, for example, constructed from a model made from an impression of the individual’s teeth, constructed and fitted for the individual by impressing the teeth into the mouthpiece, or provided by a dental professional.

A.R. 2-8. At the center draw, the umpire notices one of the players without her mouthpiece. The player then reaches into her sock, gets her mouthpiece and puts it in. **RULING:** ILLEGAL. Minor foul for not wearing her mouthpiece properly. Appropriate delay of game card is issued. Because the player was able to correct the problem immediately, she does not have to leave the game unless she is to receive a green/red card. The opposing center is awarded the ball at the spot where the draw was to take place, and the offending player moves 4m away.

Eye Protection

SECTION 9. All field players must properly wear eye protection. Eye protection must meet the most current ASTM Specification Standard F803 for women’s lacrosse, must be tested at a PECC-approved testing facility, and must be listed on the US Lacrosse Web site.

Other Personal Equipment

SECTION 10. Close-fitting gloves, nose guards and soft headgear may be worn by all players. Further protective devices necessitated on genuine medical grounds may be used by players, providing that the umpires agree that they do not endanger other players. All protective devices used should be close-fitting, padded where necessary, and not be of excessive weight.

Players may only wear securely taped medic-alert jewelry with information visible and close-fitting cloth sweatbands. Any other adornment will be considered jewelry and may not be worn. Barrettes are legal as long as they do not endanger other players.

No equipment, including protective devices, may be used unless it complies with the rules or manufacturers’ specification and is deemed not dangerous to other players by the officials.

A.R. 2-9. A field player asks to wear a hard helmet to protect an injury. **RULING:** ILLEGAL. A player cannot wear a hard helmet that would be dangerous to other players. She could wear a soft helmet made of foam-type material.

A.R. 2-10. A player is wearing a soft cloth bracelet. **RULING:** ILLEGAL, minor foul. This is considered jewelry.

A.R. 2-11. A field player is wearing a hard-brimmed baseball cap. **RULING:** ILLEGAL. A player may not wear/use any type of equipment that is dangerous to other players. Players may wear soft-brimmed visors or caps.

Uniforms

Footwear/Cleats

SECTION 11. Players must wear composition or rubber soled shoes. No spikes are allowed. Plastic, leather or rubber cleats-studs may be worn. Shoes and socks are not required to be identical for team members.

Uniform Shirts and Kilts/Shorts

SECTION 12. All team members shall be dressed uniformly with the exception of the goalkeeper, whose colors must be of the same corresponding colors as her teammates. Her top (shirt) must be of the same color as her team; the bottom must be in agreement with the team's predominant color or be black or gray. The goalkeeper's shirt must be worn over any chest and shoulder protective equipment.

SECTION 13. All players must wear numbers, differing from others on the team, on the front and back of the uniform shirt. Numbers on the back must be a minimum of 8 inches tall; numbers on the front must be a minimum of 6 inches tall and must be centered at chest level. If a number appears elsewhere on a player's uniform (such as on the kilt, shorts, pants or on the sleeves of the shirt), it must match the number on the player's shirt. Numbers must be in a color clearly contrasting to that of the top (i.e., dark shirts must have light numbers and light shirts must have dark numbers). Non-solid-colored shirts must have the numbers superimposed on a solid color block background or outlined with a contrasting color. A player's uniform number must be the same as that recorded in the scorebook. A player not listed on the roster and/or in the scorebook by name and correct uniform number is an illegal substitute.

A.R. 2-12. A team chooses to memorialize a former player by wearing her number on the uniform shirt sleeve. **RULING:** ILLEGAL. No number other than that of the player may be worn on the player's uniform. (It is suggested that the memorialized player's initials be used, or that a ribbon or arm band be worn in her memory.)

A.R. 2-13. A red player number 00 plays goalkeeper the first half of the game. The second half, she plays in the field as number 32. **RULING:** LEGAL, if both numbers were recorded on the roster that is placed at the scorer's table before the start of the game; but it must be noted in the scorebook. All warnings and cards must be carried with her name and recorded in the scorebook.

SECTION 14. The coaches/schools shall agree upon contrasting colors before the day of the game. If both teams have uniform shirts of the same or similar color, the home team shall be obligated to change or wear numbered pinnies or vests of a contrasting color.

Visible Undergarments

SECTION 15. All visible undergarments worn under the kilts/shorts must be of one solid color, and must be white, gray, black or one of that team's uniform colors. All team members choosing to wear visible undergarments must wear the same color. This does not apply to medical sleeves.

SECTION 16. All visible undergarments worn under the shirts must be of one solid color, and must be white, gray, black or one of that team's uniform colors. All team members who choose to wear visible undergarments must wear the same color. This does not apply to medical sleeves.

RULE 3

Game Personnel

The Teams

SECTION 1. A game is played between two teams. Twelve players constitute a full team, one member of whom acts as the speaking captain. Any number up to 12 players of each team may be on the field of play at the same time. One of the 12 players on each team may be a goalkeeper.

The Coach

SECTION 2. Each head coach and the officials will meet at the scorer's table with 10 minutes showing on the pregame clock. Each coach will verbally certify to the umpires that all equipment is legal under these rules, including eye protection that meets the most recent ASTM Specification Standard F803, and goalkeeper helmets that meet the NOCSAE standard for lacrosse.

SECTION 3. The head coach shall be in control of and be responsible for the actions of any and all people officially connected with his or her institution. Coaches shall assist the officials in keeping the game under control. It shall be their duty, upon the request of an official, to control effectively actions of spectators not in conformity with standards of proper conduct.

SECTION 4. Other coaching responsibilities include:

- a. Designating an acting captain if the captain leaves the field.
- b. Indicating a substitute for an injured or suspended player.
- c. Approaching the umpire pregame, at halftime or during timeouts for clarification of rules.
- d. Requesting a timeout from the umpire.

Game Administrator

SECTION 5. It is strongly recommended that the host team assign a representative to handle game management issues. When a contest is played at a neutral site, one team must be designated as the home team. The game administrator will ensure that a timekeeper and scorer are on hand with all equipment required by these rules to carry out their respective functions, and that the playing field is in proper condition for safe play and meets the specifications outlined in these rules. In the event that an administrator is unavailable, these duties will be the responsibility of the home team coach.

Team Captain

SECTION 6. The captain's responsibilities are:

- a. To call the coin toss (visitors' call) for choice of ends with the umpire.
- b. To indicate that her team is ready to play at the beginning of each half.
- c. To approach the umpire for clarification of rules.

- d. To request a timeout from the umpire.

The Umpires

SECTION 7. It is highly recommended that three officials be used to umpire the game. A minimum of two officials must be used. It is recommended that the umpires be on site 60 minutes before the start of the game and must be on the field and in charge of the game 30 minutes before game time. The umpires' jurisdiction extends from 30 minutes before the game begins until the umpires leave the playing venue.

The umpires will enforce the rules and umpire the game in accordance with the recommended procedures put forth by these rules. They should refrain from enforcing any rule when it would penalize the nonoffending team.

In games for which an alternate or table official is assigned, he or she will follow the duties outlined in Appendix G of these rules.

SECTION 8. Before the game, the umpires will inspect the grounds, goals, balls, crosses, clothing, shoes, jewelry and protective equipment and see that they are in accord with the rules.

Note: The umpires will obtain verbal certification from the head coach that all equipment is legal under these rules, including eye protection that meets the most current ASTM Specification Standard F803 for Women's Lacrosse at the appropriate level of play (adult), and goalkeeper helmets that meet the NOCSAE Lacrosse Helmet Standard.

SECTION 9. Other umpire responsibilities include:

- a. Ensuring that the timers and scorers understand their responsibilities.
- b. Informing the timer about the length of halftime if other than 10 minutes.
- c. Being available for questions from captains or coaches. A coach from the opposing team must be given the opportunity to be present during any communication with the officials by either team.
- d. After consultation with the game administrator and coaches from each team, make the final decision on whether to continue a game due to weather conditions or any other extenuating circumstances.
- e. At the end of the game verify all cards given and the final score and sign the NCAA Carding/Score Verification Form before leaving the field.

Official Scorer

SECTION 10. The official scorer will be from the home team and will sit at the scorer's/timer's table opposite the center circle. If the official scorer is not seated at field level, the home team is responsible for ensuring that the scorer's table is manned.

SECTION 11. The official scorer will assume the following duties:

- a. Record the starting lineups of both teams in the scorebook 10 minutes before the game and make sure the numbers of the players on the field correspond to the numbers in the book. Changes to the lineup cannot be made until the game starts. A roster with names and numbers of all players must be at the scorer's table before the start of the game.

- b. Keep an accurate record of the goals scored in the official home team scorebook. It is recommended that the visitors have a scorer and book at the table.
- c. Display continuously an accurate score, for the players, coaches and umpires.
- d. Accept substitutes and enter their names and numbers before they enter the game.
- e. Notify the umpire on the first ensuing stoppage of play if there has been an illegal substitution.
- f. Record any cards next to the player's name in the scorebook: delay of game (green-"g," green/yellow-"gy," green/red-"gr"); warning (yellow-"y"); or ejection (red "r"). Any card issued to the head coach must also be recorded in the scorebook.
- g. Notify the umpire immediately when a second warning is given to the same player.
- h. Record the delay of game suspensions, including the time on the game clock when a player is suspended.
- i. Record the time on the game clock when a player is given a yellow or red card.
- j. Notify the umpire when a 10-goal differential exists.
- k. Present an accurate NCAA Carding/Score Verification Form to the umpires for their signature immediately after the game ends.

A.R. 3-1. A coach attempts to change his/her lineup after it has been given to the scorer and five minutes before game time. **RULING:** No changes to the lineup will be allowed fewer than 10 minutes before the game. The only exception is a change due to injury.

Official Timer

SECTION 12. The official timer will be from the home team and should sit at the scorer's/timer's table opposite the center circle.

SECTION 13. If the official timer is not seated at field level, the home team is still responsible for ensuring the following duties are performed:

- a. Stop the clock at the whistle and arm signal after each goal. If there is a 10 or more goal differential, the timer will not stop the clock, except in the last two minutes of each half.
- b. Start the clock on the whistle at each draw.
- c. Sound a horn at the first stoppage of play:
 1. To notify the umpire of an illegal substitute.
 2. If a clock has malfunctioned.
 3. When a 10-goal differential occurs.
- d. Sound the horn to indicate a timeout request by the team in possession during a dead-ball situation only.
- e. Notify the umpire when there are two minutes remaining in each half of the game.
- f. During the last two minutes of each half of the game, stop the clock on every whistle, then restart the clock on the umpire's whistle.

- g. Indicate to the nearest umpire when there are 30 seconds remaining in each half.
- h. Sound a horn to indicate the end of the half and the end of the game.
- i. Stop the clock for any other circumstances only upon the timeout signal and whistle from the umpire.
- j. Notify the umpire when a team requests a timeout and use a separate clock to time the timeout.
 - 1. Time two minutes.
 - 2. Blow the horn at one minute, 45 seconds.
 - 3. Blow the horn at two minutes.
- k. Note the time on the clock when a player is issued a green/red card for delay of game, time the two-minute elapsed playing time penalty and notify the carded player when the penalty time has ended.
- l. Note the time on the clock when a player is issued a yellow or red card, time the two-minute elapsed playing time penalty and notify the carded player when the penalty time has ended.

Note: The home team must ensure that direct two-way communication is available at all times between the press box and the scorer's table if official scoring and/or timing functions are not handled at field level.

RULE 4

Time Factors and Scoring

Time Factors

Duration of Play

SECTION 1. The regulation playing time is 60 minutes (two 30-minute halves). Halftime will be 10 minutes, but may be less than 10 minutes if agreed upon by the coaches before the start of the game due to extenuating circumstances. Players must change ends to begin the second half. Play should be continuous, but at the discretion of the umpire, timeout may be taken for unusual circumstances, for example, a broken crosse, animal on the field, lost ball, a ball that has gone too far out of bounds, spectator interference, or delay of game. Timeout must be taken in case of illness, accident or injury, for the issuance of a card, when a free position will be awarded to the attack on the 8m arc (including the “hanging” hash marks), to check a crosse, and anytime the draw must be retaken. EXCEPTION: When the 10-goal rule is in effect (See Rule 4-3), no timeout should be called for the 8m free position on the arc or for a redraw.

SECTION 2. In all games, the clock is to be stopped on the umpire’s whistle and arm signal after each goal during the entire game, and on every whistle (to stop play) in the last two minutes of each half.

SECTION 3. If a team is leading by 10 or more goals, the clock will continue to run after goals (no stop clock). If the difference becomes fewer than 10 goals, the stop clock is reinstated. The clock is stopped on every whistle (to stop play) in the last two minutes of each half.

A.R. 4-1. A foul is called with 2:03 remaining on the clock. Play is not resumed until the clock reads 1:57. A coach argues that the timer should have stopped the clock at 2:00. **RULING:** The timer was correct to let the clock run. The clock stops for every whistle to stop play that occurs within the last two minutes of each half.

Team Timeouts

SECTION 4. Each team shall be permitted two timeouts during regulation game time that do not carry over into overtime. During the entire duration of overtime, each team is permitted one timeout. Timeout may be requested by a coach or any player on the field after a goal is scored or any time the requestor’s team is in clear possession of the ball. If a possession timeout is called, players must leave their crosse in place on the field and return to that same place for the restart of play. No substitutions will be allowed during this stoppage of play. The timeout shall be two minutes in duration commencing at the time the umpire calls the timeout. It is the responsibility of the coaches to gather their teams and to disburse them back onto the playing field. After one minute, 45 seconds, a warning horn will sound.

At two minutes, the horn will sound again. A minor foul will be called if a team is not ready to start after two minutes. Successive timeouts will not be allowed.

Note: If a possession timeout is requested and play will resume with a free position, the umpire should set up the free position, signal for the timeout and then allow the teams to leave the field.

Suspended/Interrupted Game

SECTION 5. Once play begins, the umpires shall have the authority to interrupt or suspend the game due to dangerous weather or field conditions. The umpire's decision is final. A game is considered legal and complete if 80 percent (48 minutes) of playing time has elapsed. If a suspended game (one in which less than 80 percent of playing time has elapsed) is replayed on another day, it must be played from the beginning. An interrupted game continued on the same day shall be restarted from its point of interruption.

Note: If 80 percent of the playing time has elapsed and the game is tied, leagues should determine their own tie-breaking procedures.

For NCAA tournament play, all games must be played to completion. If a tournament game is suspended and played on another day, it will be played from the point of interruption.

Forfeited Game

SECTION 6. If a team leaves the field and refuses to play, the score of the game shall stand, if the team remaining on the field was leading at the time. Otherwise, the score of the game will be 1-0 in favor of the team remaining on the field.

If a suspended or ejected coach or nonstudent team personnel refuses to leave the area, the official may declare a forfeit. The score of a forfeited game will be 1-0 in favor of the nonoffending team. If the suspended or ejected individual is a student, that individual may remain in the team bench area.

Overtime Procedures

SECTION 7. When the score is tied at the end of regular playing time, both teams will have a five-minute rest and toss a coin for choice of ends. Six minutes (two three-minute periods) of stop-clock overtime will be played. The clock will be stopped after three minutes of play in order for teams to change ends with no delay for coaching. The game will be restarted by a center draw. The team that is leading at the end of six minutes wins the game.

If the teams are still tied after six minutes have elapsed, the teams will have a three-minute rest and change ends. The winner will then be decided on a "sudden-victory" stop-clock overtime of not more than six minutes in length with the teams changing ends after three minutes. The game will be restarted by a center draw. The team scoring the first goal wins the game.

Play will continue with "sudden-victory" stop-clock overtime periods of six minutes in length with three minutes in between and change of ends until a winning goal is scored.

Scoring

SECTION 8. The team scoring the greater number of goals is the winner. A goal is scored by the whole ball passing completely over the goal line, between the posts, and under the cross-bar from in front, having been propelled by the legal crosse

of an attacking player, or the crosse or person of a defending player. If a violation of jewelry, eye protection or mouthpiece rules is discovered immediately after a goal, the goal counts and the free position is taken at the center circle.

SECTION 9. A goal is not scored when:

- a. The ball is put through the goal by a nonplayer.
- b. The ball comes off the person of an attacking player.
- c. The ball enters the goal after the whistle has blown or the horn has sounded.
- d. The player shooting has stepped on or into the goal circle, or any other attacking player has entered the goal circle.
- e. The goalkeeper, while within the goal circle, is interfered with in any way by an attacking player.
- f. The field umpire has ruled that the shot or follow-through is dangerous.
- g. The ball enters the goal while the attacking team has an illegal player on the field.
- h. The ball enters the goal when the attacking team is offside.
- i. The ball enters the goal from a crosse that does not meet specifications. If the player who shot the goal adjusts her crosse after an umpire's request for a crosse inspection, the goal will not count, and the crosse will be removed from the game.

Note: The goalkeeper's crosse must meet field crosse specifications in order to score a goal.

- j. The ball enters the goal when a shot is taken from an indirect free position.

A.R. 4-2. During the game, a goalkeeper with the goalkeeper's crosse, outside her goal circle, tosses the ball back into her circle. In doing so, the ball goes into the goal. **RULING:** Goal. A goal may be scored off the crosse or person of a defending player.

A.R. 4-3. The attack shoots and scores a goal. The umpire immediately realizes that the attack is offside. **RULING:** The umpire should sound her whistle, have everyone stand and indicate no goal. In this instance, the goalie is the closest defender to the ball and she will be awarded a free position in her goal circle. The attack player who shot the ball will go 4m behind the goal circle. The attack player closest to the restraining line will move back outside.

A.R. 4-4. A goalkeeper, with a goalkeeper's crosse, throws the ball the length of the field from her goal circle, and it goes in her opponent's goal. **RULING:** ILLEGAL, no goal. She may not score, for her team, with the large goalkeeper's crosse. A minor foul is called, and a free position is awarded to the opposing goalkeeper in her goal circle. The goalkeeper who shot the ball is allowed to remain in her goal circle.

RULE 5

Play of the Game

Start/Restart of the Game

SECTION 1. Each half of the game and overtime period, and after each goal, the game is started by a draw, except when a free position or a throw at the center line has been awarded. There must be 12 players on the field before the start unless a team does not have 12 eligible players in uniform or is playing with fewer than 12 as a result of a card or cards being issued. A maximum of **three** players from each team may be between the restraining lines during the draw until the whistle blows. All other players must be below either restraining line. Players must not enter the circle or cross the restraining lines until the whistle blows.

Note: When the game starts/restarts with a free position or throw at the center line rather than with a draw, player positioning for the draw will apply.

A.R. 5-1. The umpire has the two centers in position for the draw. As she is backing out and blowing the whistle to start, one of the centers fails to draw up and away. The umpire blows her whistle to indicate an illegal draw and awards a free position to the nonfouling center. Must all other players return to their original positions? **RULING:** No, players must simply remain where they were when the whistle blew to indicate a foul. The game restarted with a draw, then a free position was awarded as a result of a foul.

A.R. 5-2. As A1 scores a goal, B1 roughly checks the player to the ground. The umpire signals goal and then requests a timeout. She issues a card for dangerous play, either yellow or red, to B1 and sends B1 from the field. How is play restarted? **RULING:** Player B1 is out of the game for two minutes of elapsed playing time and no substitute may take her place. Player positioning for the draw will apply. Allow players to take their legal positions, blow the whistle and have everyone stand; administer the free position at the center line. The center for Team B is placed 4m away from Team A's center at a 45-degree angle. No player from Team B is placed 4m behind.

A.R. 5-3. As time expires in the half, B1 checks A1 in the head. The umpire blows her whistle and issues a card to B1. How is play restarted? **RULING:** The game is restarted with a free position for Team A's center at the center line. Player B1 is out of the game for two minutes of elapsed playing time and no substitute may take her place. Player positioning for the draw will apply. Allow players to take their legal positions, blow the whistle and have everyone stand; administer the free position at the center line. The center for Team B is placed 4m away from Team A's center at a 45-degree angle. No player from Team B is placed 4m behind.

A.R. 5-4. Timeout has been taken after a goal, and as the teams are walking to their benches, B1 (on Team B's bench) verbally abuses the umpire. The umpire issues a red card to the head coach. How is play restarted? **RULING:** After the timeout ends, play is restarted with a free position for Team A's center at the center line. The head coach for Team B must designate a player who will leave the field, enter the penalty area, and serve the two-minute nonreleasable penalty. The head coach for Team B is ejected from the game and must leave the area, including the spectator area. The center for Team B is not placed 4m behind, but must move 4m away from the player with the ball. Player positioning for the draw will apply.

The Draw

SECTION 2. The opponents each stand with one foot toeing the center line. The crosses (shaft and head combined) are held in the air, above hip level with the

lower side above the center line and back to back, so that the players' crosses are between the ball and the goal they are defending. The entire length of both crosses must be contained within the vertical plane of the center line. A player's top hand may not contact any part of the sidewall or pocket. The ball is placed between the crosses by the umpire and must be placed in the upper third of each head at its widest point. On the word "ready," the players taking the draw must remain motionless, except for head movement, until the whistle. On the whistle, the two opponents must immediately draw their crosses up and away from one another. The flight of the ball must attain a height higher than the heads of the players taking the draw.

Note: The lower side of the crosse is defined as the right side of the crosse as the player looks at it with the open pocket facing her.

SECTION 3. An illegal draw results in a free position for the opponent at the center line. For the free position, a player from the offending team is placed 4m (4.4 yds.) away to either side at an angle of 45 degrees to the center line toward the goal she is defending. If both players draw illegally or it cannot be determined why the draw was illegal, the umpire will call timeout, and a redraw will occur. EXCEPTION: When the 10-goal rule is in effect (See Rule 4-3), no timeout should be called for a redraw.

Start/Restart of Play

SECTION 4. The whistle is used to stop and start play. When starting play, the umpire also will give a visual arm signal by raising the arm above the head and moving it down to the side as the whistle is blown. The only exception to this is in the case of a "throw" in which the visual arm signal is the actual arm movement forward on the toss of the ball as the umpire blows the whistle. The timer's horn will indicate the end of each half and overtime.

Stand

SECTION 5. The ball is "dead" when the umpire blows the whistle, and no player, except the goalkeeper or her deputy within the goal circle, may move unless directed by the umpire, until the game has been restarted. The umpire directs any player who moves to return to her original position.

Restraining Line

SECTION 6. A team must:

- a. Have five players behind the restraining line when the ball is in their offensive end.
- b. Have four players behind the restraining line when the ball is in their defensive end.

Note: Players may exchange places during play, but a player should have both feet out before a teammate can enter. Any part of the foot on or over the line is considered a violation. Players may reach over with their stick to play the ball, as long as no part of the foot is on or over the line.

Out of Bounds

SECTION 7. When the ball goes out of bounds, the umpire blows the whistle to stop play, and the players must "stand." Except in the case of a shot or deflected shot on goal, when a player in possession of the ball carries or propels the ball out of bounds, or when a player is the last to touch a loose ball before the ball goes out

of bounds, the opponents will be awarded the ball when play resumes. Carrying/throwing the ball out of bounds is a simple change of possession, not a foul.

SECTION 8. When a player's foot/feet is out of bounds, she may not take an active part in the game (Minor foul). During the game, players may not run out of bounds and re-enter to a more advantageous position (Minor foul).

SECTION 9. When a player has possession of the ball and steps on or over the boundary line, or any part of her body or crosse touches the ground on or over the boundary line, the ball is out of bounds, and the player will lose possession.

- a. A player is in possession of the ball when the ball is in her crosse and she can perform any of the normal functions of control, such as cradle, carry, pass or shoot.
- b. A player in possession of the ball may hold her crosse outside the boundary as long as her foot/feet is not on or over the boundary line. If an opponent who is inbounds legally checks a player's crosse causing the ball to fall to the ground out of bounds, possession will be awarded to the opponent when play resumes.
- c. When an opponent illegally causes a player in possession of the ball to go out of bounds, the ball carrier will maintain possession of the ball when play resumes. The opponent will be penalized for a major foul.
- d. If a player deliberately pushes, flicks or bats the ball into an opponent's feet or body in order to cause the ball to go out of bounds, it will be penalized as a major foul.

SECTION 10. When a loose ball touches the boundary line or the ground outside the line, the ball is out of bounds. The player/team that last touched the ball before it went out of bounds will lose possession of it, unless it was a shot or a deflected shot on goal.

SECTION 11. To resume play when the ball has gone out of bounds:

- a. The opponent nearest the ball will place the ball in her crosse and stand 2m inside the boundary from the spot where the ball went out of bounds. If the goalkeeper while within her goal circle is the nearest to the ball when it crosses the boundary, she will remain in her circle to restart play.
- b. Any other player(s) directly involved in the play or in the immediate vicinity of the spot where the ball went out of bounds may also be moved. They must maintain the same relative position to the player with the ball that they occupied when the whistle blew to stop play. Opponents must give the player with the ball at least 1m of free space (stick and feet).
- c. All other players must maintain the field position they had when the whistle blew to stop play. Play is resumed with the whistle.

Note: Players should move only upon the direction of the umpire.

SECTION 12. When a shot or deflected shot on goal goes out of bounds, the player who is inbounds and nearest to the ball when it crosses the boundary will place the ball in her crosse and stand 2m inside the boundary line from the spot where the ball went out of bounds. Opponents must give the player with the ball at least 1m of free space. If two opposing players are equidistant from the ball (stick or body) when it goes out of bounds, a throw will be awarded.

If the goalkeeper while within her goal circle is the nearest to the ball when it crosses the boundary, she will remain in her circle to restart play.

SECTION 13. A shot or deflected shot remains a shot until the ball goes out of bounds, the ball comes to rest on the field of play, a player gains possession of the ball, or a player otherwise causes the ball to go out of bounds. It is the umpire's responsibility to determine if a thrown ball is a shot.

Note: A deflected shot is one that goes directly out of bounds after hitting the goal post or the goalkeeper's crosse or body. A ball that rebounds off the goal post, the goalkeeper, or the goalkeeper's crosse and then off any field player's crosse/body or the umpire's body and directly out of bounds will be considered a deflected shot on goal. A deflection occurs when any player merely touches the ball with her crosse or body and does not gain any distinct/clear advantage or control the ball.

SECTION 14. When the ball goes directly out of bounds from a legal draw, the umpire will call timeout, and the draw will be retaken. EXCEPTION: When the 10-goal rule is in effect (See Rule 4-3), no timeout should be called for a redraw.

A.R. 5-5. A Red defense player is in pursuit of the Blue attacker with the ball. The Red player runs out of bounds to avoid a legal pick and comes back onto the field in a position where she makes a check on the Blue attacker. **RULING:** ILLEGAL. A player may not run out of bounds and re-enter to a more advantageous position. A minor foul should be called against the Red defender.

A.R. 5-6. A Red defense player leaves the field during play to talk with her coach near her bench area. As she returns to the field, the Blue team has the ball along the opposite sideline boundary. **RULING:** LEGAL. The Red player did not re-enter the field in a more advantageous position.

A.R. 5-7. A loose ball is rolling toward the sideline boundary. A Red player runs to the ball and is able to stop it from rolling out of bounds. Her momentum then carries her out of bounds as the ball comes to rest still in play. The Red player stops, turns, re-enters the field and picks the ball up to continue with play. **RULING:** LEGAL. The Red player returned to the position on the field she occupied before her momentum carried her out of bounds, not to a more advantageous position.

A.R. 5-8. A Red player near the sideline attempts to pick up a loose ball but instead kicks the ball out of bounds. **RULING:** No foul, this is simply a change of possession on a ball out of bounds. The ball is awarded to the nearest Blue player, and she is positioned 2m inside the boundary from the spot where the ball went out of bounds. The umpire should reposition any other players if necessary before play is restarted.

A.R. 5-9. A Blue player attempts a pass across the field to her teammate. The teammate misses the pass but deliberately plays it off her body to prevent the ball from going out of bounds. **RULING:** ILLEGAL. A minor foul for a body ball should be called. The Blue player used her body to impede or change the direction of the ball.

Goal Circle Rules

SECTION 15. Only one player, either the goalkeeper or the person deputizing for her, is allowed in the goal circle at any one time. With the following exceptions, no other players are allowed to enter or to have their feet, body or crosse on or over the goal circle at any time.

- a. On a shot, the shooter may follow through with her crosse over the goal circle. Her feet must not touch the goal circle. The attacker's shooting motion must be initiated from outside the goal circle.

- b. On a shot, the player(s) directly defending the shooter may reach into the goal circle with her crosse(s) to block the shot or check the shooter's crosse. A defender's feet must not touch the goal circle.

SECTION 16. The goalkeeper while within the goal circle:

- a. Must clear the ball within 10 seconds after it has entered the goal circle.
- b. May stop the ball with either hand and/or body as well as her crosse; if she catches the ball with her hand, she must put it in her crosse and proceed with the game.
- c. Must remove a ball lodged in her clothing, protective equipment or goalkeeper's crosse, place it in her crosse, and proceed with the game.
- d. May reach out her crosse and bring the ball back into the goal circle provided no part of her body is grounded outside the goal circle.

A.R. 5-10. The goalie stops a shot and the ball rebounds off her body and is now on the ground outside the goal circle. The goalie reaches out and "rakes" the ball back into her circle.

RULING: This is a legal play provided that no player from the other team is within playing distance and is disadvantaged because the goalie covered the ball. If an opponent could have played the ball, the goalie will be called for a minor foul.

SECTION 17. The deputy:

- a. May only enter or remain in the goal circle when her team has possession of the ball.
- b. Must immediately leave the goal circle when her team loses possession of the ball.
- c. May go into the goal circle to prevent a rolling ball from crossing the goal line.
- d. While within the goal circle, must clear the ball within 10 seconds after it has entered the goal circle.
- e. While within the goal circle, must remove the ball lodged in her clothing or crosse, place it in her crosse and proceed with the game.

A.R. 5-11. A team chooses to have 12 field players on the field with no one wearing the protective equipment mandated for the goalkeeper. **RULING:** LEGAL. However, no one has the privilege of going into the goal circle to block a shot.

A.R. 5-12. A member of the team with no properly dressed goalkeeper runs into the goal circle to prevent a rolling ball from crossing the goal line. **RULING:** LEGAL. She has entered the goal circle after the shot has been taken and while the ball is on the ground. The defending team must still clear the ball within 10 seconds and immediately vacate the goal circle if/when her team loses possession of the ball.

SECTION 18. Once a team gains possession of the ball in the goal circle and the ball is cleared, the team must not intentionally return the ball to its goal circle until the ball has been played by another player.

SECTION 19. When the goalkeeper or anyone deputizing for her is outside the goal circle:

- a. She loses all her goalkeeping privileges.
- b. She may only re-enter the goal circle without the ball.
- c. She may propel the ball into the goal circle and then follow it in.
- d. She must return to the goal circle to play the ball if it is inside the circle.

A.R. 5-13. The goalkeeper comes out of the goal circle and obstructs the free space to goal.

RULING: ILLEGAL. Free position to the attacking team, and the goalie goes 4m behind.

The goalkeeper assumes all responsibilities of a field player when she leaves her goal circle.

The Throw

SECTION 20. The two players must stand with feet and crosses at least 1m (1.1 yds.) apart and the defender is nearer to the goal she is defending. The umpire stands between 4m and 8m (4.4 yds. and 8.8 yds.) from the players and on the whistle throws the ball with a short high throw so that the players take it as they move in toward the game. The throw is taken where the incident or foul occurred that caused play to stop except that no throw is taken within 8m (8.8 yds.) of the goal circle or 4m (4.4 yds.) of the boundaries. No players may be within 4m (4.4 yds.) of the players taking the throw. If the throw is inaccurate or is not touched by either player, the throw is taken again. A throw is taken when:

- a. The ball goes into the goal off a nonplayer, with the throw being taken to the side of the goal by two opposing field players nearest to the goal.
- b. The ball goes out of bounds as the result of a shot or deflected shot, and two opposing players are equally near the ball.
- c. It cannot be determined which team caused the ball to go out of bounds.
- d. There is an incident unrelated to the ball, and players are equidistant from the ball.
- e. A ball lodges in the clothing of a field player or umpire.
- f. Two players commit offsetting fouls (major and/or minor), or after the attacking team fouls during a slow-whistle situation.
- g. The game is restarted after any incident related to the ball when neither team has possession and two opposing players are equally near the ball, unless the incident has been caused by a foul.
- h. The game is stopped for any reason not specified in the rules.

A.R. 5-14. As a draw is to be taken, both teams are found to have jewelry on. **RULING:** A throw is taken for offsetting fouls. Time is out after a goal. Players must remove the jewelry. If a player cannot remove it without delay, a substitute must replace her.

A.R. 5-15. The defense is called for an illegal check. Once play has stopped, the umpire discovers that both the attack and the defense are offside. **RULING:** A throw is awarded for offsetting fouls. A player from each team closest to the restraining line should be moved back onside. The umpire should pick one player from each team closest to the spot where the play ended and below the restraining line to take the throw. The umpire should avoid taking the throw too close to the restraining line.

A.R. 5-16. The umpire is holding whistle on an offside by the defense because the attack is on a scoring play. The attack charges into the defense player. **RULING:** A throw is awarded for offsetting fouls. The defense player closest to the restraining line should be placed back onside. The umpire should pick one player from each team and administer a throw. The throw should not be taken within 8m of the goal circle.

A.R. 5-17. Defense player B1 is called for an illegal check against A1. Play is stopped and A1 is awarded a free position. Before play is restarted, the umpire notices that A1 is wearing jewelry. **RULING:** A throw is awarded for offsetting fouls. A1 must remove the jewelry before play is resumed.

A.R. 5-18. Attack player A1 is checked in the head by B1. The umpire calls timeout, issues a card to B1 and awards A1 a free position. As B1 is leaving the field, she is pushed by A2. The umpire issues a card to A2 and sends both players from the field with no substitutes allowed. How is play restarted? **RULING:** Because Team A committed a subsequent foul before play

had restarted, there is a change of possession at the site of the ball. A member of Team B closest to this spot will be moved to take the free position. A1 and all other players should be moved 4m away from the player now taking the free position. Because each team is playing a person down, no player from Team A is placed 4m behind.

Substitution

SECTION 21. Each team may substitute an unlimited number of players at any time during play (including overtime), after every goal and at halftime. During a substitution because of injury or player suspension, or if a player is sent from the field for any reason, no other players may substitute or exchange positions on the field. In these situations, the umpire will make sure that any substitute assumes the same location as the player she is replacing and that no advantage is gained. Timeout is not taken for substitution during the normal course of play. Re-entry is permitted.

Substitution Procedures

SECTION 22. Before entering the game, any substitute must report to the scorer's table. Players may enter the game using the following procedures:

- a. *During Play:* The player must enter the game through the substitution area and not enter this area until her substitution is imminent. A substitute must not go onto the field until the player she is replacing has entered the substitution area (this includes the goalkeeper). The player exiting the field has the right of way, and any players in the substitution area must yield their position and allow her to exit. No other players shall be in this area except those involved in the imminent substitution. Substitutes must not block the view of scorer's table personnel.

Note: A guideline to follow when judging "imminent": When the player wishing to sub has called the name of the player to come off the field and that player is in the act of running to the substitution area, then a substitution is imminent.

- b. *After a Goal:* After reporting to the scorer's table, any substitutes may enter the game immediately. The umpires will ensure that all replaced players leave the field before the game restarts.
- c. *Injury:* Substitution, not to exceed 30 seconds, must be made in case of injury. **EXCEPTION:** In the event of an injured goalkeeper, if the backup goalkeeper is in the game as a field player she will be permitted time to put on the goalkeeper equipment and replace the injured goalkeeper. A player from the bench may replace that field player. If a free position is to be taken and a team has no substitute available, the umpire may move the nearest player to assume the position of the player who left the field.
- d. *Player Suspension/Ejection:* No substitution will be allowed. **EXCEPTION:** If the player receiving a yellow card is the goalkeeper and there is no other "dressed" goalkeeper for her team, the goalkeeper may remain in the game, and the team's coach must designate another player who must leave the field for two minutes of elapsed playing time. If the goalkeeper receives a second yellow card or a red card, she may not return to the game. The team may substitute another goalkeeper, and the team's coach must designate another player who must leave the field for two minutes of elapsed playing time.

A.R. 5-19. The goalkeeper is hurt, while in the goal circle, and the backup goalie is on the field in the third man position. The backup goalie leaves the field during the injury timeout to put on goalkeeper equipment. When play is to resume, she is in the goal circle. **RULING:** LEGAL.

If the backup goalkeeper is in the game as a field player, she will be allowed to assume the position of the injured goalkeeper when play is to resume.

Illegal Substitution

SECTION 23. Should an illegal substitution occur, the umpire will call a timeout and remove the illegal player. The penalty for illegal substitution is a free position for the opposing team at the spot where play was to resume before the illegal substitution occurred. For breach of this rule simultaneously, the umpire will award a throw at the spot where play was to resume. If, before a goal is scored, a team is discovered to have an illegal player(s) on the field, the player(s) will be removed, and a free position will be awarded to the opposing team at the spot where play was to resume before discovery of the illegal player(s). If the spot cannot be determined, play will resume at the spot where the ball was when the error was discovered.

If an illegal player is discovered on the attacking team after a goal is scored and before play is restarted, the goal shall not count, the illegal player shall be removed, and a free position shall be awarded to the opposing goalkeeper.

Note: An extra player, suspended/ejected player, or a player not listed or incorrectly listed on the roster and/or in the scorebook at the start of the game is considered an illegal substitute. A player not listed by name and uniform number before the game may be added to the roster and/or scorebook when the error is discovered and a penalty imposed against her team.

A.R. 5-20. A player is found to be wearing jewelry. **RULING:** ILLEGAL, minor foul. If it can be removed without delay, the player may remain on the field. If not, she must leave the game, and a substitute must replace her.

A.R. 5-21. Player A is running toward her team substitution area when the whistle blows to stop play. She continues moving and attempts to complete the substitution. **RULING:** ILLEGAL. She must be directed to return to her original position when the whistle blew. After the whistle is blown to restart play, she may move to complete the substitution. Continued violation should be penalized as an intentional delay of game.

Accident, Interference, or Any Other Incident

SECTION 24. If the game has to be stopped due to an accident, injury or illness, interference, or an incident either related or unrelated to the ball at the time the whistle is blown, the game is restarted in one of the following ways:

- a. If a foul has occurred, a free position is awarded on a spot determined by the umpire. Play shall not be restarted within 8m (8.8 yds.) of the goal circle or within 4m (4.4 yds.) of the boundaries.
- b. If no foul is involved in the stoppage of play, the ball is given to the player who was in possession, or nearest to it, at the time play was stopped, and play is restarted at the spot of the ball. If two players are equidistant from the ball, a throw is taken.

A.R. 5-22. An incident off the ball causes play to be stopped. There is no foul, and the person in possession of the ball is only 3m from the goal circle. **RULING:** The player with the ball and all those around her will remain where they are, and play will be restarted at the spot of the ball.

SECTION 25. Timeout is called at the discretion of the umpire. No one from the sideline may come onto the field without the permission of the umpire, and no sideline personnel may come onto the field for the purpose of coaching. No player may leave her area of the field for the purpose of being coached. If medical

personnel or a coach comes onto the field to attend to an injured player, or if a player is bleeding, that player must leave the field. A substitute must take her place. If a free position is to be taken and a team has no substitute available, the umpire may move the nearest player to assume the position of the player who left the field. If the injured player is the goalkeeper and there is no other “dressed” goalkeeper for her team, the goalkeeper may remain in the game.

Ball Lodged in Clothing or Crosse

SECTION 26. When the ball lodges:

- a. In the clothing of a field player, a throw is taken with the nearest opponent.
- b. In the crosse of a field player, the crosse no longer meets specifications and must be removed from the game immediately. A minor foul is called, and the umpire will take timeout to remove the crosse.
- c. In the goal netting, or in the protective equipment, clothing or crosse of the goalkeeper while she is within the goal circle, she removes the ball, places it in her crosse and proceeds with the game.
- d. In the clothing of an umpire, a throw is taken by the nearest two opponents.

Equipment Inspection

SECTION 27. The head coach is required to verbally certify that all his or her team’s equipment is legal under these rules. At any time before or during the game, the umpires may inspect any equipment in use.

All crosses that might be used in the game must be inspected by the umpires before the game begins. At any time during the game, at the umpire’s discretion, timeout may be called to inspect any crosse in use. The umpires must perform a minimum of two re-inspections per half, each time checking one crosse per team. The timing of these mandatory reinspections is at the discretion of the umpires.

- a. Should the crosse meet specifications, the game shall be restarted by the ball being given to the player who was in possession of the ball, or closest to the ball if there was no possession, when timeout was called.
- b. Should the crosse not meet specifications, it shall be removed from the game by the umpire and placed at the scorer’s table for the remainder of the half. Any equipment not meeting specifications may be re-inspected (at halftime or before any overtime period) by the umpire for use in the second half or overtime period. After the removal of the crosse not meeting specifications, the game shall be restarted with a free position to the opponent nearest the ball when play was stopped. However, if the illegal crosse is an offsetting foul, a throw will be taken.

Note: The player found to have an illegal crosse will be allowed to enter the bench area to obtain another crosse and immediately return to her place on the field. No substitutes are allowed during this stoppage of play.

- c. In the event that a goal was scored with a crosse that does not meet specifications, the goal shall not count, the crosse shall be removed, and play shall be resumed with a free position for the opposing goalkeeper. Once the game is restarted with the draw, the goal shall stand. If after a goal is scored and before the game is restarted with the draw, any player other

- than the shooter is found to have a crosse not meeting specifications, a free position will be taken at the center by the opposing team.
- d. The umpire shall inspect the pocket of any player's crosse upon request of the opposing coach or any opposing player on the field. After two requests for inspection for which the crosse is found to be legal, any additional requests for inspection of any crosse meeting specifications will result in a minor foul.
 - e. The head coach may ask for a stick measurement either pregame up until 15 minutes before the scheduled start of the game or at the beginning of halftime. No request for a measurement will be allowed once the game begins except at the beginning of halftime. This request will count as an official stick check request. Officials will only measure the overall length of the stick and the distance between the sidewalls as outlined in Appendix E, Section 11 (wooden stick) or Section 18 (plastic head).

RULE 6

Fouls

Major Fouls

SECTION 1. The following are major fouls:

- a. **Rough/Dangerous Check:** Roughly or recklessly checking/tackling another player's crosse. (The direction of the check must be away from a 7-inch sphere around the head.) A crosse may be checked, in a direction toward the body, if the check/tackle is controlled, and the crosse or ball does not go into the sphere. A player may reach into the sphere to make a safe check/tackle. No player's crosse may hit or cause her opponent's crosse to hit the opponent's body.
- b. **Check to the Head (MANDATORY CARD):** No player's crosse may hit or cause her opponent's crosse to hit the opponent's head.
- c. **Slash (MANDATORY CARD):** Swinging the crosse at an opponent with deliberate viciousness or recklessness.
- d. **Holding:** Holding an opponent's crosse when the opponent is in possession of the ball.
- e. **Crosse in the sphere:** Holding her crosse within the sphere around the face or throat of an opponent.
- f. **Illegal Contact:** Initiating crosse-to-body, or body-to-crosse contact.
- g. **Cross-Check:** Using the shaft of the crosse to hit, push or displace an opponent. This includes, but is not limited to, thrusting, jabbing, pushing or displacing any part of an opponent's body.
- h. **Illegal Use of the Crosse:** Using the crosse in a dangerous and/or intimidating manner, for example:
 1. Directly poking or waving the crosse near an opponent's face;
 2. Making a sweeping check from behind that contacts the opponent's body;
 3. Lowering the head of the crosse below shoulder level and initiating crosse-to-body contact; or
 4. Any other action with the crosse that, in the umpire's opinion, amounts to dangerous or intimidating play.
- i. **Hooking:** Using the webbed area of her crosse to hook the bottom end of an opponent's crosse.
- j. **Reach across the body:** Reaching across an opponent to check the crosse when she is level with or behind her.
- k. **Illegal cradle:** Holding, with or without cradling, the head of her crosse in front of her face or her teammate's face, within the sphere or close to her body, or her teammate's body, making a legal/safe check impossible.

- l. **Blocking:** Blocking her opponent by moving into her path without giving her a chance to stop or change direction.
- m. **Charging:** Charging, barging, shouldering or backing into an opponent.
Note: Body-to-body contact may be called charging, blocking or no call (incidental contact). Crosse-to-crosse contact is either a legal or illegal check.
- n. **Pushing:** Pushing the opponent with the hand or body.
- o. **Obstruction of the Free Space to Goal (shooting space):** With any part of her body, guarding the goal outside the goal circle so as to obstruct the free space to goal, between the ball and the goal circle, which denies the attack the opportunity to shoot safely and encourages shooting at a player.
 - 1. This positioning applies only if initiated by the defender and not if she is drawn into the free space to goal by an attacking player.
 - 2. This positioning applies to a defender not marking a player within a stick's length.

Note 1: This call should be made only if the player with the ball is looking to shoot. If she is being double- or triple-teamed and she has no opportunity to shoot for goal, the call should not be made. If the player with the ball is outside the 12m fan area, she must be advancing toward goal and looking to shoot, or the call should not be made.

Note 2: Defense players who are double- or multiple-teaming a player without the ball and are within a stick's length are exempt from the obstruction of free space to goal. They must, however, continue to abide by the three-second rule.

- p. **Three Seconds:** While defending within the 8-meter arc, remaining in that area more than three seconds unless one is marking an opponent within a stick's length. The three-second rule is in effect when the team in possession of the ball crosses the ball over the restraining line into its attacking end of the field.

The defense is not exempt from the three-second rule by virtue of double-teaming/multiple-teaming a non-ball attack player in the arc. The three-second count will continue against the original nonmarking defense player within the arc, until there is again only one defender on the non-ball attacker.

A defensive player who is marking an unmarked opponent who is standing directly behind the goal circle is exempt from the three-second rule, but is responsible to simultaneously abide by the shooting space rule. A defensive player who is marking an unmarked opponent who is standing directly behind the goal circle cannot be penalized for the three-second rule when drawn into a double- or multiple-team by the attacking non-ball players.

- q. **Illegal Pick:** Setting a moving or stationary pick out of the visual field of an opposing player that does not allow enough time or space to stop or change direction and contact occurs.
- r. **Tripping:** Tripping an opponent, deliberately or otherwise.
- s. **Detaining:** Detaining an opponent at any time by holding or pushing against her body, clothing or crosse with an arm, leg, body or crosse. A player may not hold her crosse in such a manner as to restrain or hold back a player.

- t. **Forcing Through:** While in possession of the ball, trying to force her crosse through an opposing crosse(s) in such a way as to cause her own crosse to contact her body.
- u. **False Start:** Before the whistle, stepping or making any movement simulating the beginning of play designed to gain an advantage over one's opponent.
- v. **Playing the Ball off an Opponent:** Pushing, flicking or batting the ball into an opponent's feet or body causing the ball to go out of bounds.
- w. **Dangerous Propelling (MANDATORY CARD):** Propelling the ball with her crosse in a dangerous or uncontrolled manner at any time.

Note: Any shot directed at or taken without regard to the positioning of a field player is dangerous propelling.

- x. **Dangerous Follow-Through (MANDATORY CARD):** Following through with her crosse in a dangerous or uncontrolled manner at any time.
- y. **Dangerous Shot:** Shooting dangerously or without control.
 1. A dangerous shot is judged on the basis of the combination of distance, force and placement.
 2. A shot should not be directed at the goalkeeper's body, especially her head or neck. This would not apply if she moves into the path of the ball.
 3. A shot may be uncontrolled even if it misses the goal.
- z. **Illegal Shot:** Shooting from an indirect free position.

Note: Repeated violations of minor fouls should be penalized as major fouls. Any minor foul done in a dangerous manner may be penalized as a major foul.

A.R. 6-1. Incidental contact occurs between A1 and B1 when both are going for the ball. **RULING:** NO CALL. Realize some incidental contact may occur when two players are going for the ball.

A.R. 6-2. Attack player A1 has the ball in front of the goal between 12 and 15m, and her teammate A2 is being guarded deep and to the side of the goal circle by a defensive player. The low attack (A2) player begins to run across the goal, and her defense (D2) player decides to stop and tries to play the attack (A1) player, moving straight on to her, more than a stick's length away. **RULING:** ILLEGAL. Major foul, obstructing free space to goal. The defense must approach from an angle. The defense cannot run directly at A1 (body-to-body), with her body in the free space to goal. She would be legal if she ran at an angle with the body out of the free space to goal. The defender is permitted to hold her stick in the free space to goal.

A.R. 6-3. Attack (A1) shoots on goal, the ball goes into the goal as A1 hits the defender (B1) on the shoulder with her follow-through. **RULING:** ILLEGAL. No goal; free position for B1 8m from the goal. A card (yellow or red) must be given to A1. No substitution is allowed, and no player from Team A is placed 4m behind B1.

A.R. 6-4. An attack player false starts when she has a free position at an 8m hash mark. She is warned and given a second chance. **RULING:** Incorrect procedure. False start is a major foul with a change of possession.

Minor Field Fouls

SECTION 2. The following are minor field fouls:

- a. **Covering:** Guarding a ground ball with her foot or crosse.
- b. **Empty Stick Check:** Checking/tackling or holding an opponent's crosse when her crosse is not in contact with the ball. This applies only if the opponent could have received or gained possession of the ball.

- c. **Warding Off:** Guarding the crosse with an arm. If one hand is removed from the crosse, the free hand may not be used to ward off an opponent, deliberately or otherwise, with or without contact. Elbows may not be used to protect the crosse.
- d. **Hand Ball:** Touching the ball with her hand, except the goalkeeper or deputy within the goal circle.
- e. **Squeeze the Head of the Crosse:** Using her hand or body to keep the ball in the crosse, that is, squeezing the head of the crosse.
- f. **Body Ball:** Allowing any part of her body to deliberately impede, accelerate or change the direction of the ball. However, if the goalkeeper blatantly attempts to stop a shot on goal by playing the ball off her body while outside the goal circle, it shall be called a major foul.
- g. Throwing her crosse in any circumstance.
- h. Taking part in the game if she is not holding her crosse.
- i. **Illegal Draw:** Drawing illegally.
 - 1. Either player draws too soon.
 - 2. No attempt is made to draw up and away.
 - 3. Movement of the crosse is not up and away.
 - 4. Player taking the draw moves after the umpire says “ready” and before the umpire’s whistle.
 - 5. Ball does not go higher than the heads of the players taking the draw.
 - 6. Player steps on/into the center circle or illegally crosses the restraining line before the whistle.
- j. **Illegal crosse:** Playing with a crosse that does not meet specifications.
- k. Scoring a goal with a crosse that does not meet the field crosse specifications.
- l. Adjusting the strings/thongs of her crosse after an official inspection of her crosse has been requested during the game. The crosse must be removed.
- m. Requesting, for a third time (or any additional) the inspection of any crosse meeting specifications.
- n. Failing to be ready to start play after a two-minute team timeout or after halftime.
- o. **Jewelry:** Taking part in the game if she is wearing jewelry.
- p. **Illegal Uniform:** Taking part in the game if her uniform does not meet specifications.
- q. **Illegal Substitution:** Substituting illegally.
- r. **Delay of Game:** Intentionally delaying the game:
 - 1. Failure to stand when the whistle is blown to stop play (creeping).
 - 2. Failure to move 4 meters away on a free position.
 - 3. Failure to properly wear a mouthpiece.
 - 4. Failure to properly wear eye protection.
 - 5. Any type of behavior that, in the umpire’s opinion, amounts to delay.

- s. **Play from out of bounds:** Taking an active part in the game when her foot/feet are out of bounds.
- t. **Illegal re-entry:** Running out of bounds and re-entering to a more advantageous position.
- u. **Illegal Timeout:** A team requesting more than two timeouts.

A.R. 6-5. On a slow whistle, the scoring play has ended, and the attack has been awarded a free position. The umpire notices that an attack player is not wearing a mouthpiece. **RULING:** ILLEGAL. Minor foul, give appropriate delay of game card. A throw is awarded for offsetting fouls.

A.R. 6-6. As a number of players are attempting to gain possession of a ground ball, the ball takes a bad bounce, hits off the back of B1's leg and goes directly to her teammate B2. **RULING:** LEGAL. B1 did nothing deliberate to the ball in this instance, and no foul should be called.

A.R. 6-7. A1 attempts a pass across the field to her teammate A2, who is standing alone near the sideline. As the ball approaches, A2 realizes she won't be able to stop it with her stick. She uses her leg and makes contact with the ball to slow the ball and prevent it from going out of bounds. **RULING:** ILLEGAL. A2 used her leg to deliberately impede or change the direction of the ball.

Goal Circle Fouls

SECTION 3. A field player must not enter or have any part of her body or crosse on or in the goal circle at any time except in the following circumstances:

- a. She is deputizing for the goalkeeper.
- b. The shooter may follow through with her crosse over the goal circle; however, her feet must not touch the goal circle, and her shooting motion must be initiated from outside the goal circle.
- c. The player(s) directly defending the shooter may reach into the goal circle with her crosse(s) to block the shot or check the shooter's crosse; however, the defender's feet must not touch the goal circle.

SECTION 4. A field player must not enter or remain in the goal circle illegally as a deputy.

SECTION 5. The goalkeeper or her deputy must not:

- a. Allow the ball to remain in the goal circle longer than 10 seconds.
- b. When inside the goal circle, reach beyond the goal circle to play the ball in the air or on the ground with her hand.
- c. When any part of her is grounded outside the goal circle, draw the ball into her goal circle.
- d. Step back into the goal circle when she has possession of the ball.
- e. When outside the goal circle, throw any part of her equipment to her deputy.

SECTION 6. Once a team gains possession of the ball in the goal circle and the ball is cleared, the team must not intentionally return the ball to its goal circle until the ball has been played by another player.

Team Fouls/Offside

SECTION 7. A team must have five players behind the restraining line when the ball is in their offensive end, and must have four players behind the restraining line when the ball is in their defensive end.

Note: Players may exchange places during play, but the player should have both feet out before a teammate may enter. Any part of the foot on or over the line is considered a violation. Players may reach over with their stick to play the ball, as long as no part of the foot is on or over the line.

Misconduct

SECTION 8. The following are misconduct fouls:

- a. Excessively rough, dangerous or unsportsmanlike play.
- b. Persistent or flagrant violation of the rules.
- c. Deliberately endangering the safety of an opposing player.
- d. Baiting or taunting that is intended or designed to embarrass, ridicule or demean others.
- e. Excessive dissent or abusive language.
- f. Nonplaying team member leaving the team bench area during the game.
- g. Coach leaving his/her coaching area.
- h. Re-entering the game before yellow card or green/red card penalty time has elapsed.
- i. Any type of behavior that, in the umpire's opinion, amounts to misconduct.

A.R. 6-8. Defender B1 is marking an attack player A1 in front of the goal, and the attack player with the ball (A2) shoots at goal; at the last second, A1 ducks out of the way. **RULING:** This can be dangerous play. A free position can be awarded to the defensive player and a card given to the shooter.

RULE 7

Penalty Administration

General Penalty Administration

SECTION 1. The penalty for fouls is a “free position.” In the event of two players committing offsetting fouls, a throw is taken. Repeated or persistent minor fouls may be penalized as major fouls. Repeated or persistent major fouls may be carded. Timeout must be taken for the issuance of a card.

Repeated major fouls and any unsportsmanlike act of a violent nature by a player or coach occurring anywhere on the field may be penalized at the 8-meter arc of the offending team. The free position is taken by the closest player on the field to the center hash mark. No players are moved, except the one taking the free position and as necessary to clear the 8m arc. Play is resumed with the whistle.

SECTION 2. The umpire indicates where the player taking the free position is to stand. No player or her crosse is allowed within 4m (4.4 yds.) of the player taking the free position; if anyone is within this distance, she must move to a position indicated by the umpire. No free position may be taken closer than 4m (4.4 yds.) to a boundary line. No free position may be taken closer than 8m (8.8 yds.) to the goal circle, except by the goalkeeper who may be awarded a free position inside the goal circle.

SECTION 3. If any foul prevented an almost certain goal, the umpire can order the goalkeeper from between such a free position and the goal.

A.R. 7-1. The goalie is out of the goal circle when a foul is called against the defense. The resulting free position calls for the arc to be cleared with the goalie remaining outside the goal circle. As the whistle blows to start play, the attack player prepares to take a shot at the undefended goal. A defender flagrantly obstructs the free space to goal. The umpire blows her whistle immediately, thus stopping the shot. **RULING:** Obstruction of the free space to goal requires an immediate whistle from the umpire. Because the foul prevented an almost certain goal, the umpire must remove the goalkeeper from the goal circle. The umpire must issue a red card to the player who committed the flagrant foul.

Free Position—Placement of Players

Major Fouls

SECTION 4. For major fouls anywhere on the field, the offending player will stand 4m (4.4 yds.) behind the player taking the free position. This also applies to the goalkeeper or her deputy, whether she is within or outside the goal circle. A verbal caution or warning may be given. When the goalkeeper is awarded a free position within the goal circle, the player committing a major foul is placed 4m behind the goal circle.

A.R. 7-2. An attack player is running down the far side of the field with the ball. The umpire calls timeout to warn an attacking teammate who has been verbally abusive. **RULING:** Issue a yellow card for misconduct. Change of possession at the site of the ball.

Minor Fouls

SECTION 5. For minor fouls anywhere on the field, the offending player will stand 4m (4.4 yds.) away in the direction from which she approached before committing the foul. This applies to the goalkeeper if she is wholly outside the goal circle. For minor fouls involving jewelry, illegal uniform, or failure to wear a mouthpiece or eye protection, a substitute must replace the offending player unless correction can be made without delay.

Team Fouls/Offside

SECTION 6. If the attack fouls, the closest defender to the spot of the ball will be awarded a free position at that spot (no closer than 8m to the goal circle). The attack player with the ball will go 4m behind; the attack player closest to the restraining line will move back outside. If the attack player with the ball is closest to the line, the next closest attack player will move back outside.

Note 1: If the attack has possession of the ball, the whistle should sound as soon as the violation occurs.

Note 2: If the attack is offside but the defense gains possession of the ball before the foul can be called, the umpire may hold whistle and not penalize the offside if the defense is able to maintain the advantage and clear over the restraining line to go on attack.

SECTION 7. If the defense fouls and the ball is outside the critical scoring area or below the goal line extended when the violation is called, the attack will be awarded a free position at that spot (not closer than 8m to the goal circle). The closest defender will go 4m behind; the defender closest to the restraining line will move back outside.

SECTION 8. If the defense fouls and the ball is inside the critical scoring area and above the goal line extended when the violation is called, the attack will be awarded a free position at the center of the 12m fan. The closest defender will go 4m behind; the defender closest to the restraining line will move back outside; the penalty lane will be cleared; and the goalkeeper may return to the goal circle.

Note: The entire goal circle is considered to be above the goal line extended.

SECTION 9. If the defense fouls and the play ends with another major foul by the defense:

- a. Inside the 8m arc: Penalize this foul, not the offside foul.
- b. Outside the 8m arc, but inside the 12m fan: Penalize this foul, not the offside foul.
- c. Outside the 12m fan/inside the critical scoring area: Penalize the offside foul (move the free position up to the top center of the 12m fan, clear lane).

Note: Violation of the restraining line by the defense may be a held whistle. The umpire must evaluate if the attack is on a scoring play/maintaining advantage.

A.R. 7-3. The ball is below the restraining line with the attack in possession. Defense causes a turnover, but the whistle then sounds for an offside foul by the defense. Where is the free position taken? **RULING:** If the ball is outside the critical scoring area or below the goal line extended, the free position is awarded at that spot. If the ball is inside the critical scoring area and above the goal line extended, or inside the goal circle, the free position is awarded at the top center of the 12m fan. Attack with the ball to the spot of the free position; nearest defender placed 4m behind; closest defender to the restraining line will move back outside.

A.R. 7-4. The goalkeeper has moved outside her goal circle to play the ball when offside is called on the defense. The free position is being awarded at the top of the 12m fan. Is the goalkeeper allowed to return to the goal circle? **RULING:** Yes, she may move back into her goal circle.

Goal Circle Fouls

SECTION 10. The penalty for goal circle fouls by the defense other than for an illegal deputy shall be a free position taken 8m out to either side, level with the goal line. The offending player, except the goalkeeper, shall be placed 4m behind the player taking the free position. The goalkeeper remains on the spot of the foul, or if she was within or partially within the goal circle, she remains inside the circle.

The penalty for goal circle fouls by the attack shall be a free position taken by the goalkeeper, or her deputy, within the goal circle.

The penalty for an illegal deputy shall be treated as a major foul. The free position will be awarded to the attack at the 8-meter center hash mark, the deputy will be put 4 meters behind, and the goalkeeper may NOT clear back into the goal circle.

A.R. 7-5. A goalkeeper is grounded, straddling the goal circle, and pulls the ball back into the crease. **RULING:** ILLEGAL. Goal circle foul. The goalkeeper may return to the goal circle, and the free position is taken 8m out to either side level with the goal line.

Resumption of Play

SECTION 11. The player awarded the free position takes the ball in her crosse, and on the whistle with arm signal from the umpire, the game is restarted. The player may run, pass or shoot. **EXCEPTION:** The player taking an indirect free position may not shoot until the ball has been played by some other player.

Special Situations - Placement of Players

In the Critical Scoring Area, Outside the 8-Meter Arc

SECTION 12. For a major foul by a defense player, the free position will be taken on the spot of the most recent foul. All players' bodies and crosses must be cleared sideways from the penalty lane relative to their position at the time of the whistle. The goalkeeper in the penalty lane may clear back into the goal circle if she did not foul.

In the 8-Meter Arc

SECTION 13. For a major foul by a defense player that occurs in the 8-meter arc, all players' bodies and crosses must be cleared from the 8-meter arc and penalty lane if necessary. The goalkeeper may clear back into the goal circle if she did not foul. All players must take the shortest route out. The player who was fouled will move to a hash mark nearest the spot of the foul, on the 8-meter arc. The player who fouled moves to the 12-meter fan directly behind the player taking the free position.

Note: In taking the shortest route out of the arc, the arc is cleared relative to one's position inside the arc. The intent of clearing the arc is not to further penalize the defense. In other words, if a defensive player is ball-side of an offensive player when the whistle is blown, the defense is entitled to a ball-side position on the arc, not necessarily at a hash mark. If a defensive player is not ball-side when the game is stopped, she is not entitled to that position on the arc.

SECTION 14. For a major foul by a defense player which occurs outside the 8-meter arc, and the scoring play ends inside the 8-meter arc without an additional foul occurring, the free position will be taken on the spot of the foul by the player who was fouled or attack player nearest to the spot of the foul. All players' bodies and crosses must be cleared sideways from the penalty lane relative to their position at the time of the whistle.

Minor Field Fouls Inside the 12-Meter Fan

SECTION 15. When a minor foul by a defense player occurs in the 12-meter fan and the slow whistle rule is not in effect, the player fouled will move to the nearest spot on the 12-meter fan. All other players shall remain in their same positions with the exception of the fouling defense player, who shall move 4m from the player taking the free position, relative to her position at the time of the foul. This is an indirect free position, and no shot may be made by the player taking this free position until the ball has been played by some other player.

SECTION 16. For a minor foul by an attack player, the player fouled will take the free position on the spot of the foul, but not closer than 8m from the goal circle, unless the goalkeeper has been fouled within the goal circle.

Note: Umpires are encouraged to hold their whistle in the event that a minor foul is committed by a defense player when the attack player may have the opportunity to shoot.

Slow Whistle

Implementation

SECTION 17. A slow whistle is a held whistle for a major foul by the defense in the critical scoring area when an attack player is on a scoring play. The umpire will indicate this slow whistle by raising a yellow flag vertically above her head.

SECTION 18. A slow whistle is in effect when an attack player in the critical scoring area is on a scoring play and is fouled by the defense committing a major foul but retains possession of the ball or when an attack player in the critical scoring area is on a scoring play and a major foul is committed against an attack teammate without the ball.

SECTION 19. The umpire immediately blows the whistle when there is an obstruction of the free space to goal. The umpire may, at any time after the flag, blow the whistle to halt potentially dangerous play.

Scoring Play

SECTION 20. A scoring play is a continuous effort by the attacking team to move the ball toward the goal and to complete a shot on goal. The scoring play is completed when:

- a. A shot is taken.
- b. The attacking team loses possession of the ball. A bounce pass is not considered loss of possession.
- c. The attacking team passes or carries the ball behind the level of the goal line and stops the continuous attempt to score.
- d. The attacking team stops the continuous attempt to score, or the player with the ball is forced by the defense to lose her forward momentum.

- e. The attacking team fouls.

Enforcement of the Slow Whistle

SECTION 21. If the attacking team chooses to shoot, the advantage indicated by the flag is complete, the umpire lowers the flag, and play continues. If the shot on goal is successful, the goal counts. A free position will be awarded to the player fouled or to the attack player nearest the spot of the foul if:

- a. The attacking team does not shoot and the scoring play ends.
- b. The shot is affected by the foul so that no advantage is gained.
- c. A cardable foul is committed by the defense.

SECTION 22. The offending or nearest defense player is penalized according to major foul conditions. The next nearest defense player may move to 4m (4.4 yds.) relative to the player with the ball. All players and their crosses must move out of the penalty lane until play is restarted.

SECTION 23. During a slow whistle situation, if there are additional major or minor fouls by the defense, the attack will be awarded the ball at the 8-meter hash mark nearest to the most recent foul at the end of the unsuccessful scoring play.

A.R. 7-6. On a slow whistle (flag has been raised), the goalkeeper commits the next foul, ending the scoring play. **RULING:** Free position to the attacking team, the arc is cleared, and the goalkeeper is placed 4m behind the 8m free position.

SECTION 24. The goalkeeper may return to her goal circle if:

- a. She has moved outside the goal circle and made an interception or any legal play on a slow whistle, thus ending the scoring play.
- b. She has moved outside the goal circle and gained possession of the ball on an out-of-bounds slow whistle, thus ending the scoring play.
- c. She has moved outside the goal circle on a slow whistle and is fouled by the attack, ending the scoring play.
- d. She is in the arc when the whistle blows and has not fouled, and the arc is to be cleared.
- e. She is in the penalty lane when the whistle blows and has not fouled, and the penalty lane is to be cleared.

SECTION 25. If during a slow-whistle situation, the attack player or one of her teammates commits a foul, it will be treated as an offsetting foul, and a throw will be taken out to the side of the field and nearest to the spot of the foul that caused play to stop, but not closer than 8m (8.8 yds.) from the goal.

Issuance of Cards

Delay of Game

SECTION 26. Timeout must be called to administer a delay-of-game card. The first violation should be followed by a green card given to the team captain. A change of possession takes place, if applicable, for the minor foul.

On the next delay of game, the umpire will show a green and yellow card to the offending player and issue the appropriate penalty (major foul). The offending player may remain in the game.

Any subsequent delay-of-game offenses will result in a green and red card being given to the offending player and issuing the appropriate penalty (major

foul). The player receiving the green/red card must leave the field and enter the penalty area for two minutes of elapsed playing time, which will carry over to the second half or overtime, if necessary. A substitute must take her place. The official timer will be responsible for timing the two minutes and indicating to the scorer when the player may return. If the player receiving the green/red card attempts to return before the penalty time has elapsed, it will be considered misconduct.

Misconduct and Suspension

SECTION 27. The penalty for misconduct shall be the same as for all major fouls. In addition to awarding a free position, the umpire will issue a yellow or red card. A yellow card is a two-minute releasable penalty. A red card is a two-minute nonreleasable penalty. Issuance of cards should be considered a warning to all players. Timeout must be called to administer warnings, suspensions and ejections.

SECTION 28. The umpire may warn the offending player by issuing a yellow card. The player receiving the yellow card must leave the field and enter the penalty area for two minutes of elapsed playing time, and no substitute may take her place during that two-minute period. If the opposing team scores during this time the player will be released from the penalty area and is eligible to re-enter the game. If the carded player or any player replacing her enters the game before the penalty time has elapsed, the player originally receiving the card will serve an additional two-minute penalty and no substitute may take her place. If the player receiving the yellow card is the goalkeeper and there is no other "dressed" goalkeeper for her team, the goalkeeper may remain in the game, and the team's coach must designate another player who must leave the field and enter the penalty area for the two-minute period.

Note: A team with a player or players in the penalty area must play short-handed in both its attacking and defensive ends of the field until the penalty time has elapsed or the opposing team scores a goal (if the player is serving a releasable penalty). If a team has more than one player in the penalty area and the opposing team scores, the player who entered the penalty area first will be the first released. If the opposing team scores again, the player who entered the penalty area second will be the next released. If a team has two players who received cards at the same time, they will both be released if the opposing team scores during penalty time. Any player serving a nonreleasable penalty must serve the full two-minute penalty.

Note: When administering a free position after a card has been issued and a team is playing a person down, no player on the penalized team must be moved 4m behind. EXCEPTION: If the goalkeeper is carded, either she or the second dressed goalkeeper who enters the game will be placed 4m behind the player with the ball on the restart of play. This exception will apply no matter where the goalkeeper is when she commits the foul, either inside or outside her circle. However, if a goal is scored and the free position as a result of the card will take place at the center, the goalkeeper or her substitute may remain in the goal circle for the restart of play.

SECTION 29. A player who receives a second yellow card must leave the field and enter the penalty area for two minutes of elapsed playing time, and no substitute may take her place during that two-minute period. She will be suspended from further participation in that game. Once the penalty time has

expired or if the opposing team scores a goal, the team may substitute another player for the player who has been suspended. If the goalkeeper receives a second yellow card, she will be suspended from further participation in that game. If the goalkeeper receives a red card, she will be ejected from the game. The team may substitute another goalkeeper, and the team's coach must designate another player who must leave the field for two minutes of elapsed playing time.

SECTION 30. The umpire has the power to eject without any previous warning a player, coach or team personnel guilty of flagrant or repeated violation of the rules, dissent, misconduct or abusive language. This immediate ejection will be noted by issuing a red card. The player receiving the red card must leave the field and enter the penalty area for two minutes of elapsed playing time, and no substitute may take her place during that two-minute period. A red card is a nonreleasable penalty. Once the full penalty time has been served, the team may substitute another player for the player who has been ejected. Any player or coach who has received a red card will be prohibited from participating in the team's next game. The next game suspension will carry over to the following season if the ejection occurs during the team's last game.

Note: A player or coach serving a game suspension shall be restricted to the designated spectator areas and prohibited from any communication or contact, direct or indirect, with the team, coaches, bench personnel and/or game officials from the start of the game to its completion, including any overtime periods. While the suspended coach or player is allowed on the field and in the bench area during pregame activities, the suspended player may not be dressed in her game uniform, and she may not take part in any warmup activities.

SECTION 31. If the carded player or any player replacing her enters the game before the penalty time has elapsed, the player originally receiving the card will serve an additional two-minute penalty, and no substitute may take her place. If the player entering early is the player who received the original card, she will be removed from the field of play for the remainder of the penalty time and then serve the additional two-minute penalty. If the player entering early is not the player who received the original card, the officials will send a player from the offending team who is closest to her team bench area off the field, and the player who received the original card will serve the remainder of the penalty time and then serve the additional two-minute penalty. A change of possession will take place at the spot of the ball if warranted, and any free position will be awarded at the spot of the ball with a player from the offending team placed 4m behind the player with the ball.

SECTION 32. A yellow or red card issued to the head coach will result in a player being removed from the field. The head coach must designate a player who must leave the field and enter the penalty area to serve the penalty time. A consecutive card issued to the same player during the same stoppage of play will not result in any additional player being removed from the field. The player will serve a two minute penalty. If the second card issued is a red card, the penalty will be nonreleasable. Once the penalty time has been served, or the player has been released, she may not re-enter the game, but the team may substitute another player.

SECTION 33. The head coach is responsible for the behavior of anyone in the team bench area and will receive any card issued for lack of bench decorum. In the event the head coach is warned, suspended or ejected, play is restarted within

one minute with a free position to the opponent nearest the ball when play was stopped. Any head coach who is suspended (two yellow cards) or ejected must leave the area (including the spectator area) of the game. In the event that any team follower is to be warned or suspended, the head coach may be assessed the penalty. In the event the head coach does not effectively control the actions of the team's spectators, the head coach may be assessed a card.

SECTION 34. If a situation occurs after the game ends and before the umpires leave the playing venue where conduct occurs that would warrant a red card during play, the umpire(s) can issue a postgame ejection to the offending player or coach to be served in the team's next game. The umpires must inform their assigner or the offending team's head coach or game administrator immediately after the game to report the ejection.

A.R. 7-7. A team follower has become unruly and abusive. The umpire approaches the appropriate head coach and asks to have this person warned and/or removed. **RULING:** Allow the coach and/or game administrator the time necessary to handle the problem. If possible, continue with the game while the situation is being resolved. If the problem persists the coach may be carded.

A.R. 7-8. The umpires have issued yellow cards for the same type of offense (e.g., slashing, dangerous/rough checks, etc.). A player who has not previously been issued a yellow card then commits a slash. The umpire calls timeout and issues a red card to the offending player. **RULING:** LEGAL. The umpires are not required to issue a verbal caution before issuing a yellow card, or a yellow card before issuing a red card. Issuance of cards should be considered a warning to all players.

RULE 8

Definition of Terms

Blocking

This takes place when a player moves into the path of a player with the ball without giving that player a chance to stop or change direction causing contact. When a player is running to receive the ball, a “blind-side” defense player must give her enough time and/or space to change her direction.

Body Checking

This is a technique whereby a defender moves with an opponent without body contact occurring, following each movement of the opponent’s body and crosse with her body and causing her to slow down, change direction or pass off.

Charging

This takes place when the player with the ball pushes into, shoulders, or backs into, and makes bodily contact with her opponent who has already established her position (though not necessarily stationary).

Checking

This is an attempt to dislodge the ball from an opponent’s crosse by using controlled crosse-to-crosse contact.

Clear

This is any action taken by a player within the goal circle to pass or carry the ball out of the goal circle.

Clear Space

This indicates the space between players that is free of crosses or any parts of the body.

Coaching Area

This is the area on the bench/table side of the field extending from the substitution area to his/her end line, and up to the sideline.

Critical Scoring Area

The critical scoring area is an area at the end of the field where the attacking team is shooting for goal. Its boundaries are approximately 15m (16.3 yds.) in front of the goal circle to 9m (10 yds.) behind the goal line extended and 15m (16.3 yds.) to each side of the goal circle. No extra lines will be marked on the field, and this will be called in the judgment of the umpire.

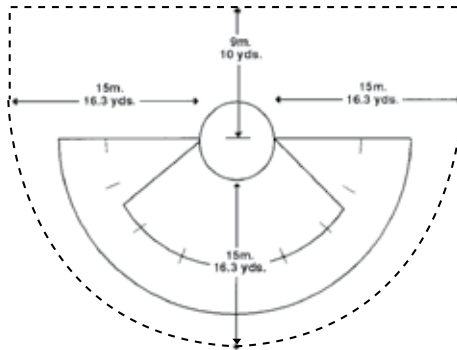

Critical scoring area

Deputy

This is a player on the defensive goalkeeper’s team who may only enter or remain in the goal circle when her team is in possession of the ball and the goalkeeper is out of the goal circle.

Directly Behind the Goal Circle

This is the area between two lines extending perpendicular and back from the goal lines extended, tangent to the goal circle.

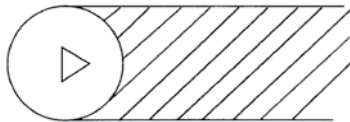

Directly behind the goal circle

8-Meter Arc

This is the area in front of each goal circle inscribed by two lines drawn at 45-degree angles extending from the intersection of the goal circle and the goal line (extended); connected by an arc marked 8 meters from the goal circle.

Field Player

This is any player other than the goalkeeper. It is a defense or attack player whose primary responsibility encompasses an area outside the goal circle and to whom no special privileges have been awarded according to the rules.

Free Space to Goal

This is a path to goal within the critical scoring area as defined by two lines extending from the ball to the outside of the goal circle. No defense player will be penalized if positioned below the extension of the goal line.

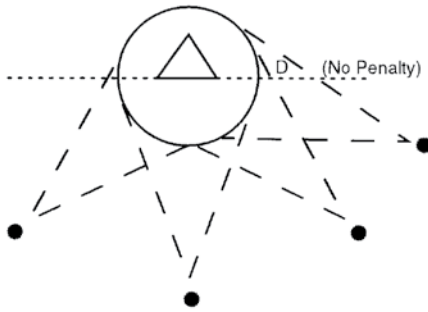

Free space to goal

Green Card

This is presented to the captain, indicating a team caution for delay of game and that the next team offense results in a green/yellow card to the offending player.

Grounded

This refers to any part of the goalkeeper's (or her deputy's) body touching the ground outside the goal circle while she attempts to play the ball from inside the goal circle.

Indirect Free Position

This is the penalty awarded for a minor field foul by the defense inside the 12-meter fan. The player taking the free position may run or pass, but may not shoot, until another player has played the ball.

Lower Side of Crosse

This refers to the wood on a wooden crosse and to the right side of a plastic crosse as one looks at the crosse with the pocket facing the player.

Marking

This is guarding an opponent within a stick's length.

Nonreleasable Penalty

Any red card offense will be considered a nonreleasable penalty. A player will serve the full two-minute penalty and will not be released back into the game under any circumstances.

Offside

This refers to a team with more players over the restraining line than is allowed by the rules.

Penalty Area

This is the area directly in front of the scorers/timer's table and at the rear of the substitution area where any player who has been carded will sit or kneel while serving their penalty time.

Penalty Lane

This is the path to the goal that is cleared when a free position is awarded to the attacking team inside the critical scoring area in an area in front of the goal line. The path is defined by the imaginary parallel lines that extend from the width of the goal circle. All other players must clear this lane when a free position is awarded in front of the goal.

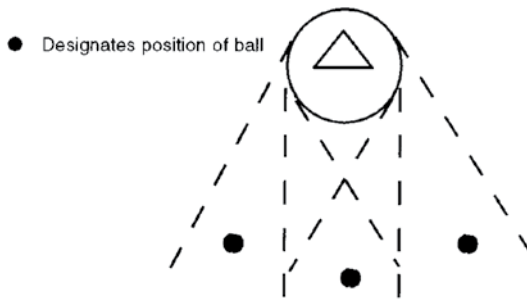

Penalty Lane

Pick

This is a technique in which a player without the ball, by her positioning, forces the opponent to take another route. To be legal, it must be set within the visual field of the opponent, allowing the opponent enough time and space to stop or change direction.

Played

This refers to an action whereby the ball leaves the player's crosse and is touched by another player, or her crosse is checked crosse to crosse by an opposing player, or play is stopped due to a foul by the defense. The ball does not have to be successfully dislodged from the crosse.

Red Card

This is given to an offending player, coach or any team personnel who is immediately ejected from the game. Anyone who has received a red card shall be prohibited from participating in the team's next game.

Releasable Penalty

A yellow card offense will be considered a releasable penalty. A player will be released from the penalty area once the two-minute penalty has been served or if the opposing team scores a goal. If a player has received a second yellow card, she may not return to the game, but her team may substitute another player.

Restraining Line

This is a solid line at each end of the field 27m (30 yds.) up field from the goal line that extends fully from one side of the field to the other side.

Scoring Play

This is a continuous effort by the attacking team to move the ball toward the goal and to complete a shot on goal. The scoring play is complete when:

- a. A shot is taken.
- b. The attacking team loses possession of the ball.
- c. The attacking team passes or carries the ball behind the level of the goal line and stops the continuous attempt to score.
- d. The attacking team stops the continuous attempt to score, or the player with the ball is forced by the defense to lose her forward momentum.
- e. The attacking team fouls.

Slashing

This is the swinging of a crosse at an opponent's crosse or body with deliberate viciousness or recklessness, whether or not the opponent's crosse or body is struck.

Slow Whistle

This is a held whistle, with flag raised, once the attack has entered the critical scoring area and is on a scoring play.

Sphere

This is an imaginary area of 18cm (7") (average crosse width) surrounding the head.

Substitution Area

This is the area in front of the scorer's table, centered at midfield, and sectioned off by two hash marks that are each 4.5m (5 yds.) from the center line of the field.

Team Bench Area

This is the area from the end of the substitution area to the team's restraining line, and behind the level of the scorer's table extended.

Toeing the Line

This refers to the placement of the foot up to, but not on, the center line.

12-Meter Fan

This is a semicircle area in front of each goal circle bounded by an arc 12m (39'4") from the goal circles.

Within a Stick's Length

This is when any part of the opponent's body is inside a crosse's length. It is the distance a player must be to her opponent to be actively marking this opponent.

Yellow Card

This is given as a warning to an offending player, coach or team personnel. A second yellow card to the same individual will result in that person being suspended from further participation in the game.

Appendix A

Pregame Protocol

This pregame protocol must be followed for every game and will allow for a standard warm-up procedure at every venue.

A 3 p.m. game time is used in this example:

Real Time	Clock Time	Activity
1:50	60:00	Field Open
2:40	10:00	Coaches/Officials Meeting
2:45	05:00	Captains' Meeting
2:50	00:00	Clear Field/Stick Check
2:55	00:00	Lineups Announced
2:57	00:00	National Anthem
3:00	00:00	Opening Draw

When an adjustment is necessary because the game is on TV or radio, there must still be 10 minutes before the start of the game when the clock is at 00:00. The protocol may be modified for special events (senior day, field dedications, etc.) provided the visiting team is notified and agrees before the game, and the officials are notified before the game.

As part of the pregame protocol, once a team's sticks are checked, the sticks should not be removed from the field of play before the start of the game. If the team or an individual player leaves the field for any reason after the completion of the stick check, all sticks must remain in the bench area. Game officials may amend this policy in situations, such as inclement weather, when teams return to the locker rooms.

Once the pregame countdown clock has started, each team will conduct any pregame warm up on their half of the playing field only.

Appendix B

Umpire Signals

Additional officiating signals are currently being developed. A full listing of signals with illustrations is available on both the NCAA and US Lacrosse websites.

Description of Arm Signals

BLOCKING: Place open hands on the hips and move them to touch hips with in-and-out motion.

CHECKING INTO THE SPHERE: Make a chopping motion with the hand close to the head.

COVER: Arms extended downward in front of body with the right palm held on top of the left palm.

DANGEROUS FOLLOW-THROUGH AND DANGEROUS PROPELLING: Fists held in front of body (with one being higher than the other) then extending outward in a throwing motion. Fist of lower hand down, fist of upper hand up like a crosse would be held.

DANGEROUS SHOT ON GOALKEEPER: Open palm in front of face moving in an in-and-out motion.

DETAINING: Place fists (one up, one down) in horizontal position in front of hips.

DIRECTION OF POSSESSION: Point with open hand in the direction of play.

EMPTY CROSSE CHECK: Use the right hand with clapping motion on the left hand.

GOAL: Turn toward the center of the field, raise arms above the head and then lower them, pointing horizontally toward the center of the field.

GOAL CIRCLE FOUL: Simultaneous directional signal with one arm, and chopping motion toward the goal circle with the other arm.

HELD WHISTLE: Arm raised horizontally, at shoulder level, in the direction of the goal the offended player is attacking.

ILLEGAL BALL OFF THE BODY: Indicate by pointing to the body part that touched the ball.

ILLEGAL CRADLE IN SPHERE: Make a cradling motion using the hand pulled in close to the face.

ILLEGAL STICK-TO-BODY CONTACT: Place fists (one up, one down) in horizontal position in front of hips. Then extend arms outward in a pushing motion.

NO GOAL: With the arms extended toward the ground, swing them out and in so that they cross each other.

OBSTRUCTION OF FREE SPACE TO GOAL: Arms held in front of the body with palms toward face, with one hand closer to the face, hands up, palms in a line about 6 inches toward the face.

OFFENSIVE FOUL: Place right hand behind head.

OFFSIDES: Raise an open hand above the head to indicate the foul. Close the fist when making the call.

PUSHING OR BODY CONTACT: Make a pushing motion with two arms out in front of the body.

RE-DRAW: Place crossed palms in front of body, begin with hands together, and then extend them up and out with a quick motion.

ROUGH CHECK/ILLEGAL CHECK ON BODY: Use the arm to make a large chop motion against the wrist of the opposite arm.

SLASH: Long swiping motion of the extended arm from high to low across the body.

10-SECOND GOAL CIRCLE COUNT: One arm, shoulder high, moving from chest (90-degree bend) to full extension.











THREE-SECOND RULE: Three fingers raised, palm away.















THROW: One hand, in an underhand motion, moving back and forth.

TIME IN: Hand open above the head with arm fully extended; then drop the arm in a chopping motion to start the clock.

TIMEOUT: Turn toward the timer and cross fully extended arms at the wrist above the head.

WARDING OFF: Use the forearm in an upward motion away from the body.

 <p>BLOCKING</p>	 <p>CHECKING INTO THE SPHERE</p>	 <p>DANGEROUS FOLLOW THROUGH & DANGEROUS PROPELLING</p>	
 <p>DANGEROUS SHOT ON GOALKEEPER</p>	 <p>DETAINING</p>	 <p>EMPTY CROSSE CHECK</p>	 <p>HELD WHISTLE DIRECTION OF POSSESSION</p>
 <p>GOAL</p>		 <p>GOAL CIRCLE FOUL</p>	 <p>ILLEGAL BALL OFF THE BODY</p>
 <p>ILLEGAL CRADLE IN SPHERE</p>	 <p>ILLEGAL STICK TO BODY CONTACT</p>	 <p>NO GOAL</p>	

 <p>COVER</p>	 <p>OBSTRUCTION OF FREE SPACE TO GOAL</p>	 <p>OFFENSIVE FOUL</p>	 <p>OFFSIDES</p>
 <p>PUSHING OR BODY CONTACT</p>	 <p>RE-DRAW</p>	 <p>ROUGH CHECK/ ILLEGAL CHECK ON BODY</p>	
 <p>SLASH</p>	 <p>THREE SECOND RULE</p>	 <p>TIME IN</p>	
 <p>TIMEOUT</p>	 <p>WARDING OFF</p>	 <p>TEN SECOND GC COUNT</p>	 <p>THROW</p>

Appendix C

Lightning Policy

The purpose of this appendix is to provide information to those responsible for making decisions about suspending and restarting games based on the presence of lightning. For complete procedures, please refer to Guideline 1d of the NCAA Sports Medicine Handbook, which may be found online at www.ncaapublications.com.

1. National Severe Storms Laboratory (NSSL) staff strongly recommends that all individuals should have left the game site and reached a safe structure or location by the time the person monitoring the weather obtains a flash-to-bang (lightning-to-thunder) count of 30 seconds (equivalent to lightning being six miles away). This recommendation was developed as a practical way to make a judgment in situations where other resources such as technology and instrumentation are not available.

In addition, a smaller, but still real, risk exists with the presence of lightning at greater distances. Unfortunately, current science cannot predict where the next strike will occur.

2. The existence of blue sky and the absence of rain are not protection from lightning. Lightning can, and does, strike as far as 10 miles away from the rain shaft. It does not have to be raining for lightning to strike.
3. When considering resumption of a game, NSSL staff recommends that everyone ideally should wait at least 30 minutes after the last flash of lightning or sound of thunder before returning to the field of activity.
4. If available, electronic detection devices should be used as additional tools to determine the severity of the weather. However, such devices should not be used as the sole source when considering terminating play.

(Information taken from the NCAA Sports Medicine Handbook and NCAA Championships Severe Weather Policy.)

Appendix D

Blood Guidelines

Outlined below is the official US Lacrosse policy regarding the handling of blood/bleeding situations during games. This policy is specific to women's lacrosse and should be followed by all teams in addition to guidelines developed by their schools.

When a player suffers a laceration or wound in which oozing or bleeding occurs, the game should be stopped at the earliest practical time, and the player should be given appropriate medical treatment. The player may return to the game with the approval of medical personnel (team doctor, trainer or other designated person with medical training). She may re-enter the game in the same half.

If the umpire stops the game because a player is discovered to be bleeding, the player must leave the game, and a substitute must enter. If the umpire stops the game because an injury has occurred, the regular injury timeout procedure is followed. If an injury timeout has been called and it is then determined that it is a bleeding problem, the player must leave the game, even if medical personnel/coach have not come onto the field, and a substitute must enter.

In cases in which a goalkeeper is discovered to be bleeding, and she is the only dressed goalkeeper for her team, the game should be stopped at the earliest practical time. She should be given appropriate medical treatment, and she may remain in the game.

If there is blood on any part of a player's uniform/personal equipment, medical personnel should determine if the blood has saturated the uniform/equipment enough to require a change. In the absence of medical personnel, the umpire(s) will make this determination. A uniform is considered saturated when blood has soaked through the uniform to the player's skin or is capable of being transferred to another player. The same saturation criteria should be applied to a player's personal equipment (stick, gloves, knee brace, etc.). If a uniform shirt is changed, the player's new number must be recorded in the scorebook before she re-enters the game.

Any playing surface contaminated with blood must be cleaned by appropriate medical personnel before the game is restarted. In the absence of medical personnel, the home team is responsible for properly cleaning the affected area.

The umpires will not make medical evaluations. Their responsibility is to keep the playing field clear of players who are bleeding, who have open wounds, or who have uniforms that may be saturated with blood.

Appendix E

US Lacrosse Manufacturer's Specifications for Equipment

Coaches and officials should access the latest version of the stick specifications on the NCAA and US Lacrosse websites.

All Field Crosses

SECTION 1. The primary intent of the field crosse specifications is to ensure that the ball moves freely within all parts of the head and pocket so that the ball may be dislodged from a crosse without an excessively forceful check. A crosse may be deemed illegal even though it meets all technical specifications if, in the opinion of the rules committee, its design is an obvious attempt to circumvent the intent of the rules. A crosse that has been altered in such a way as to give an unfair advantage to a player is illegal.

SECTION 2. The head of the crosse shall be constructed of wood, plastic, fiberglass, nylon, leather, rubber, gut, and/or any other synthetic material. The handle of the crosse shall be constructed of wood, metal alloy or other composite material and must be nominally straight. An exception is that a handle may deviate up to, but not more than, 10 degrees from straight for the last part of the shaft that is within 6.5cm from the ball stop when the handle is mounted in the head. Recessed metal screws may be used to attach the head of a plastic/molded crosse to the handle. The end of all handles shall have an end cap, be taped or be sanded smooth if wood or solid composite material. The crosse shall not have sharp or protruding parts or edges and shall not be dangerous to players in any way.

SECTION 3. The overall length of the crosse shall be 90cm minimum to 110cm maximum. End caps are included when measuring the overall length of a crosse.

SECTION 4. To determine crosse compliance with the linear measurement specifications in US Lacrosse Rule 9, all measurements shall be made to the nearest 0.01cm. The allowed deviation from the standard is 0.09cm.

Note: If the maximum specified length for a particular measurement is 5.1cm, then a measurement of 5.19cm is legal, but 5.20cm is not legal. If the minimum specified length for a particular measurement is 5.1cm, then a measurement of 5.01cm is legal, but 5.00cm is not legal.

SECTION 5. The unstrung head and the handle of a field crosse must lie within a 6.55cm horizontal plane.

- a. At the bridge or the ball stop, the top edge of the bridge or ball stop must be at least 1.3 cm above the centerline of the handle.
- b. The top edge of the sidewall must not be more than 0.6cm below the centerline of the handle.
- c. The top edge of the sidewall must not drop below the centerline of the handle before 5.7cm as measured from the center of the bridge or ball stop.

Note: To determine the 6.55cm horizontal plane of the head, place the crosse on a table with the open pocket facing up so that the long axis of the handle is horizontal to the floor. Depending on the shape of the head, it may be necessary to support the handle so it is horizontal. With the handle horizontal and the lowest part of the head in contact with the table, no part of the head as defined from the ball stop to the outside edge of the scoop shall be more than 6.55cm above the table.

SECTION 6. The overall length of the head, as measured from the center of the bridge or ball stop (where the top, back edge of the stop pad meets the plastic) to the top outside edge of the scoop, shall be 25.4cm minimum to 30.5cm maximum. With the open pocket of the head facing up, all length measurements are taken along the centerline of the handle.

SECTION 7. The overall outside width of the head of the crosse when measured at the widest point at the top of the head shall be 18cm minimum to 23cm maximum. With the open pocket of the head facing up, all width measurements are taken on a line that is perpendicular to the extension of the handle.

SECTION 8. Sidewall stringing holes: From the bottom of the sidewall to the bottom of the stringing hole shall not be more than 1 cm.

SECTION 9. The entire crosse (strung head and handle) shall not weigh more than 567g.

Wooden Field Crosses

SECTION 10. The head of a wooden field crosse is defined to consist of four parts: the bridge, the wooden sidewall, the guard and the scoop.

- a. The bridge is the woven ball stop of a wooden crosse. The height of the bridge shall be 5.1cm maximum to 3.2cm minimum.
- b. As measured from the bridge to the midpoint of the head, the height of the wooden sidewall shall be 4.5cm maximum to 3.2cm minimum. From the midpoint of the head, the height of the sidewall may taper toward the scoop.
- c. The guard is the soft woven wall of the head. The height of the guard shall be 7cm maximum to 3.2cm minimum.

SECTION 11. The head shall be triangular. The inside width between the sidewalls of the head must continually increase as measured from the center of the bridge to the widest point at the top of the head.

- a. The inside width between the sidewalls of the head, as measured 3.2cm from the center of the bridge, shall be 6.7cm to 7.6cm and the outside width of the head shall be 7.6cm to 10.1 cm.

- b. The inside width between the sidewalls of the head, as measured 5.1cm from the center of the bridge, shall be 7cm minimum.
- c. The inside width between the sidewalls of the head, as measured 7.6cm from the center of the bridge, shall be 8cm minimum.
- d. The inside width between the sidewalls of the head, as measured 10.2cm from the center of the bridge, shall be 9cm minimum.
- e. The inside width between the walls at the widest point at the top of the head shall be 15cm to 16cm.

Plastic/Molded Head Field Crosse

SECTION 12. The head of the plastic/molded head field crosse is defined to consist of four areas: the throat, the ball stop, the sidewall and the scoop.

SECTION 13. The ball stop is the center inside curved plastic wall of the head at the throat. The wall of the ball stop must not deviate by more than 7 degrees from perpendicular to the long axis of the handle. The height of the ball stop shall be 6.55cm maximum to 3.2cm minimum.

Note: To determine crosse compliance with the angular measurement specifications in US Lacrosse Rule 9, all measurements and calculations will be made to the nearest 0.01 degree. The allowed deviation from the standard is 0.44 degrees. If the maximum specified angle is 7 degrees, then a particular measurement of 7.44 degrees passes and 7.45 degrees does not.

SECTION 14. Stop pads shall not be more than 0.5cm thick. With the open pocket of the head facing up, the stop pad shall not vary in thickness from the top to the bottom of the ball stop. The stop pad may have slightly raised or inset lettering as long as the perceived goal is artistic design/advertising. The surface of the stop pad may not, in any way, interfere with the free movement of the ball within the pocket or affect ball retention.

SECTION 15. The stop area ends and the sidewall begins at 3.4cm as measured from the center of the ball stop. The sidewall ends and the scoop area begins at the widest point at the top of the head.

SECTION 16. From the beginning of the sidewall at 3.4cm to the midpoint of the head, as measured from the center of the ball stop to the top of the scoop, the actual height of the sidewalls shall be 4.7cm maximum to 2.8cm minimum. From the midpoint of the head, the height of the sidewalls may taper toward the scoop.

SECTION 17. There may be no protrusions or outcroppings on the inside surface of the sidewalls that interfere with the free movement of the ball or affect ball retention. Minor protrusions or outcroppings added for design or strengthening purposes will be allowed. The legality of these protrusions/outcroppings will be determined by the rules committee upon submission of the crosse by the manufacturer.

Note: If the testing lab determines that a crosse contains outcroppings or protrusions on the sidewalls, the crosse must be submitted to the US Lacrosse Rules Committee. The US Lacrosse Rules Committee will issue rulings on crosse legality in January and August of each year.

SECTION 18. The head of the crosse shall be triangular in concept, with the exact allowable distances between the sidewalls determined by the specific measurements outlined in other sections of US Lacrosse Rule 9.

- a. The inside width between the sidewalls of the head, as measured 3.2cm from the center of the ball stop, shall be 6.7cm minimum to 8.0cm maximum. The radius of the ball is 3.2cm.
- b. The inside width between the sidewalls of the head, as measured 5.1cm from the center of the ball stop, shall be 6.8cm minimum.
- c. The inside width between the sidewalls of the head, as measured 7.6cm from the center of the ball stop, shall be 7.4cm minimum.
- d. The inside width between the sidewalls of the head, as measured 10.2cm from the center of the ball stop, shall be 8.7cm minimum.
- e. The inside width between the walls at the widest point at the top of the head shall be 16.0cm minimum.
- f. The inside width between the sidewalls is measured by determining the minimum distance between projections of the sidewalls onto a horizontal plane. This can be performed by measuring the outside distance between two vertical rods.

SECTION 19. At all points along the sidewall, the formula outlined below shall be used to determine the maximum slant/angle that the sidewalls of the head may deviate from vertical.

- a. With the open pocket of the head facing up, measure the vertical height of the sidewall at any point. Then find the difference in the width between the top and the bottom edges of the sidewalls at that point.
- b. At all points, the difference between the top and bottom widths divided by the vertical height of the sidewall must be 0.65 or less.

The Pockets (Field Crosses)

SECTION 20. The pockets of all field crosses shall be strung with four or five longitudinal leather and/or synthetic thongs. Mesh pockets are not allowed. Longitudinal leather or synthetic thongs shall be 0.3cm to 1.0cm wide. The loose ends of the thongs may not be woven back up through the pocket of the crosse.

SECTION 21. The pockets of all field crosses shall be strung with eight to 12 stitches of cross lacing. Cross-lacing in a traditionally strung pocket is defined as eight to 12 knots/stitches, where two pocket nylon laces intertwine at a common place on a thong.

SECTION 22. Cross-lacing in a premanufactured detachable pocket is defined as 8 to 12 evenly spaced pocket nylon laces that are sewn or traditionally woven between evenly spaced longitudinal thongs.

SECTION 23. The nominal diameter of the shooting/throw string nylon cord and sidewall nylon cord shall be 0.3cm maximum. The nominal diameter of pocket nylon must be less than 0.3cm.

SECTION 24. Field crosses shall have no more than two separate shooting/throw strings. Shooting/throw strings shall not be rolled or coiled or twisted more than twice between each thong. Flat laces may not be used as shooting/throw strings.

SECTION 25. Both shooting/throw strings must be attached in the upper third of the head, or, the top shooting/throw string must be attached in the upper third in the head and the bottom shooting/throw string may be an inverted "U" in shape

and must be attached in the upper two-thirds of the head, as measured from the top outside edge of the scoop.

SECTION 26. All components of the pocket shall be integral, either by tying or by stitching. In no case shall components be slid over the shooting strings, cross lacings, or thongs. This rule strictly prohibits the use of beads, tubing, or similar items on any part of the pocket.

SECTION 27. The combined height of the sidewall and the depth of the pocket containing the ball shall not exceed 6.4cm, the diameter of the ball. The top of a ball, when placed into the pocket of a horizontally held crosse, must be visible/seen above the top of the entire wooden or plastic sidewall after reasonable force with one hand has been applied to and released from the ball.

SECTION 28. The ball must move freely within all parts of the head/pocket both laterally and along its full length. The ball must not become wedged between the walls, under the guard or under the bridge of a wooden crosse, or in the ball stop or under the walls of a plastic/molded head crosse. The ball must easily fall out of the pocket when the crosse is turned upside down.

Note: The following are some examples that either alone or in combination might cause a lack of free ball movement in the head/pocket: Shooting strings that are not interwoven with the cross lacings and thongs and allowed to sit on top of these other stringing areas; thongs that are raised above the plane of the pocket; thongs made from a sticky/tacky substance or this type of substance added to the thongs.

Goalkeeper's Crosse

SECTION 29. The crosse shall be constructed of wood, plastic, fiberglass, nylon, leather, rubber, gut, and/or any other synthetic material. The handle of the crosse shall be straight and may be constructed of wood, metal alloy or other composite material. Recessed metal screws may be used to attach the head of a plastic/molded head goalkeeper's crosse to the handle. The end of all handles shall have an end cap, be taped or be sanded smooth, if wood. The crosse shall not have sharp or protruding parts or edges and shall not be dangerous to players in any way.

SECTION 30. The overall length of the crosse shall be 90cm minimum to 122cm maximum. The end cap is included when measuring the overall length of the crosse.

SECTION 31. To determine crosse compliance with linear measurement specifications, all measurements shall be made to the nearest 0.01cm. The allowed deviation from the standard is 0.09cm.

SECTION 32. The unstrung head and the handle of a goalkeeper's crosse shall lie within a 7.6cm horizontal plane.

- a. No part of the head shall pass beyond a plane 2.5cm above the centerline of the handle and/or 5.1cm below the centerline of the handle.
- b. The top edge of the sidewall shall not be more than 0.6cm below the centerline of the handle.

SECTION 33. The head shall have a maximum length of 42cm. The length of the head is measured from the center of the bridge or ball stop (where the top back edge of the stop pad meets the plastic) to the top outside edge of the scoop. With

the open pocket of the head facing up, all length measurements are taken along the centerline of the handle.

SECTION 34. The height of the bridge or ball stop of a goalkeeper's crosse shall be 5.4cm maximum to 3.2cm minimum. The bridge or plastic wall of the ball stop must not deviate by more than 10 degrees from perpendicular to the long axis of the handle.

SECTION 35. The height of the woven wall of a wooden goalkeeper's crosse shall be 7cm maximum. As measured 3.4cm from the top center of the bridge or the ball stop, the sidewall begins. The height of the sidewall shall be 5.1cm maximum to 2.54cm minimum. The sidewall ends at the widest point at the top of the head.

SECTION 36. The entire head of the crosse shall be triangular in concept. The inside width between the sidewalls of the head must continually increase from the center of the bridge or ball stop to the widest point at the top of the head. With the open pocket of the head facing up, all width measurements are taken between the plastic or woven and wooden sidewalls on a line that is perpendicular to the centerline of the handle.

- a. When measured 5.1cm from the center top edge of the ball stop, the inside width between the sidewalls of a plastic/molded head crosse shall be 13cm to 17cm. The maximum outside width of the head shall be 20cm.
- b. When measured 10.2cm from the center top edge of the ball stop, the inside width between the sidewalls of a plastic/molded head crosse shall be 18.5cm to 22.5cm. The maximum outside width of the head shall be 26cm.
- c. When measured 15.3cm from the center top edge of the ball stop, the inside width between the sidewalls of a plastic/molded head crosse shall be 23cm to 26cm. The maximum outside width of the head shall be 30cm.
- d. At the widest point of the head, the inside width between the sidewalls of a plastic/molded head crosse shall be 28.5cm to 30.5cm. The maximum outside width of the head shall be 33cm.

SECTION 37. The pocket of the crosse may be strung with six or seven longitudinal leather or synthetic thongs and cross-lacing or may be mesh. The depth of the pocket may be unlimited except that the ball must move freely within all parts of the head and the pocket, both laterally and along its full length.

SECTION 38. The goalkeeper's crosse may have more than two shooting/throw strings. Flat laces or nylon cord may be used as shooting/throw strings. There are no restrictions regarding the design or placement of shooting/throw strings in the pocket of a goalkeeper's crosse.

SECTION 39. The entire crosse (strung head and handle) shall not weigh more than 773g.

Note: The intent of the rule governing the design of the goalkeeper's crosse is to disallow any crosse to which excessive widths of plastic have been added to the outside of the sidewalls in order to increase the surface area of the head.

Stick Testing Procedures: Any lacrosse stick to be used, sold or marketed in the United States must first be submitted to the testing lab. Once the test facility has determined that the stick meets all the specifications outlined in US Lacrosse Rule 9, a report noting this compliance will be sent to the US Lacrosse Rules

Committee Chair. The stick will then be listed on the US Lacrosse Web site as legal for use in the United States. If a stick has been submitted to the testing lab and it is determined that it meets all IFWLA specifications, it will automatically be considered legal for use in the United States. These sticks will also be listed on the US Lacrosse Web site. For more information about the testing procedures, please contact the US Lacrosse Rules Committee Chair.

The testing lab will accept pre-production models (also known as SLA's or rapid prototypes) for testing, however, only preliminary approval will be granted if the model meets all specifications. Final approval and listing on the US Lacrosse Web site will be contingent on the submission to the testing lab of a final production model that meets all specifications.

Eye Protection

SECTION 40. All eye protection must meet the most current version of the ASTM Specification Standard for women's lacrosse, either at the adult or youth level.

SECTION 41. All eye protection must be tested at a PECC-approved testing facility, and test results must be sent to the Women's Division Director, US Lacrosse. Only eye protection that has been tested by a PECC-approved testing facility will be listed on the US Lacrosse Web site and considered legal for use in women's lacrosse play.

Ball

For information on lacrosse ball specifications, please refer to NCAA Rule 2-5.

Goals

For information on lacrosse goal specifications, please refer to NCAA Rule 1-14.

Nets

For information on lacrosse goal net specifications, please refer to NCAA Rule 1-14.

Note: Specifications for all equipment are modified periodically by the US Lacrosse Women's Rules Committee. Although the committee will endeavor when possible to provide advance notification of changes to manufacturers of lacrosse equipment known to the committee, the committee expressly reserves the right to change any specification at any time if, in its sole discretion, the committee deems the change to be in the best interest of the sport of women's lacrosse. US Lacrosse does not test or approve equipment to determine compliance with specifications. US Lacrosse shall have no liability for defects caused by failure to meet specifications or for alterations made after manufactur

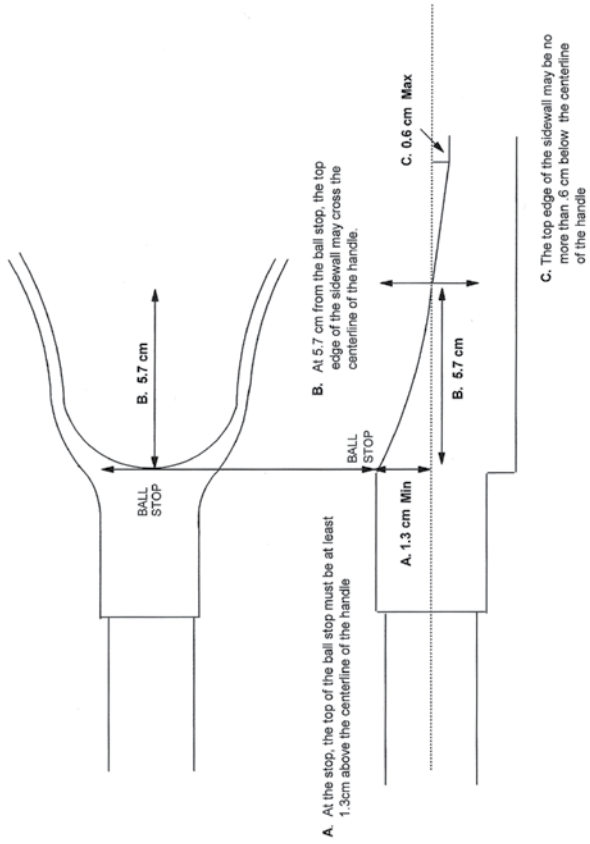

Diagram 10 - Offset specifications within 6.55 cm horizontal plane

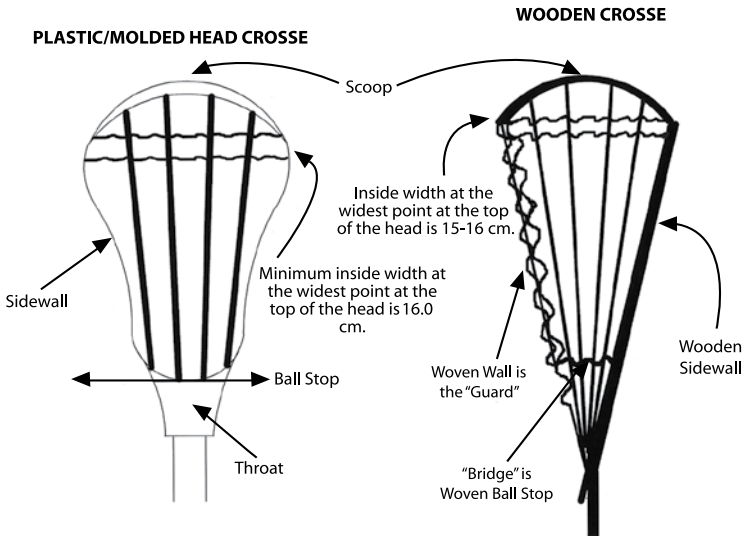

Diagram 11 - The Field Crosse

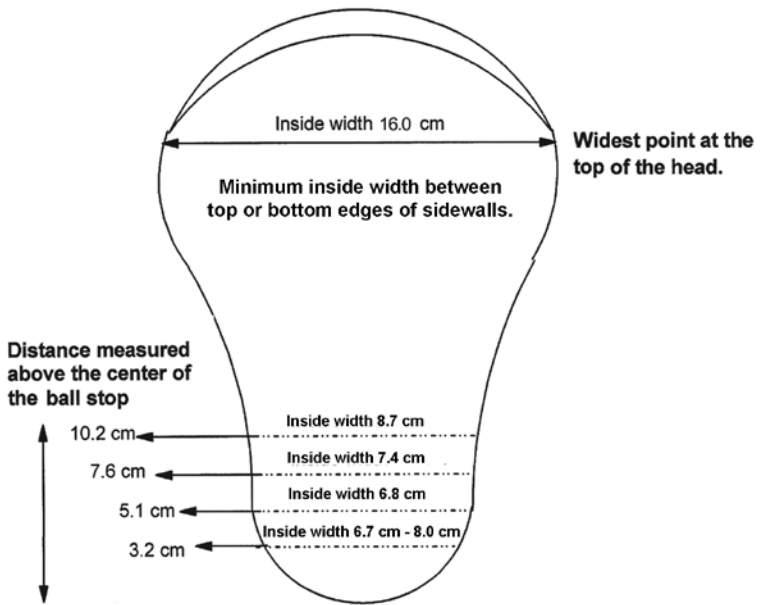

Diagram 12 - Triangular in concept

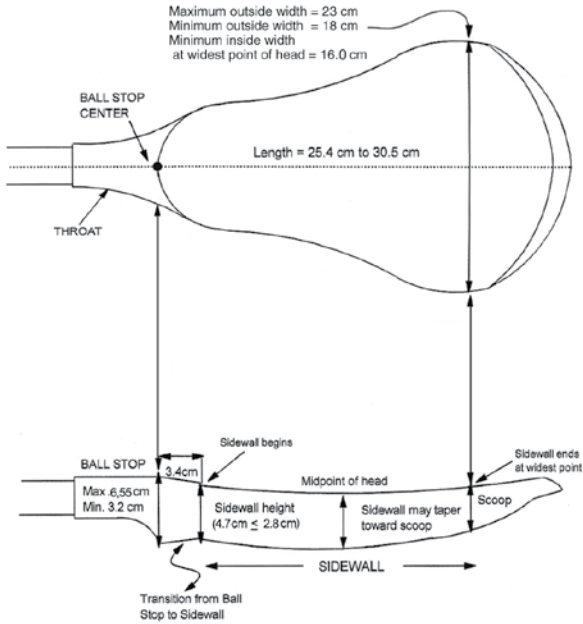

Diagram 13 - Plastic/molded head specifications

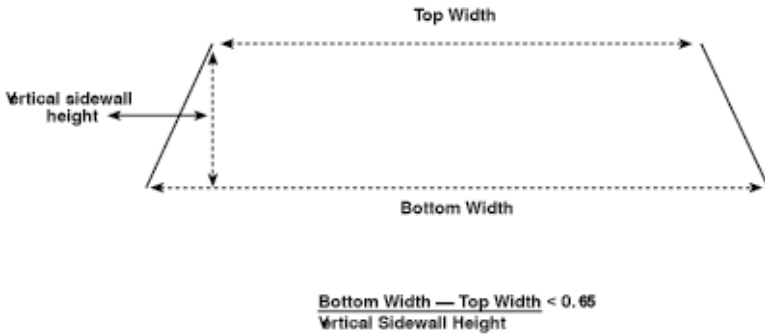
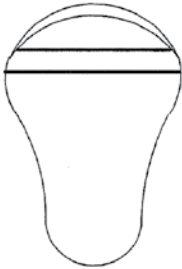
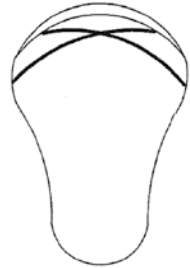

Diagram 14 - Cross section of unstrung head

Two separate horizontal throw strings; both attached in upper third of the head.



Two separate curved throw strings; both attached in upper third of the head; may not be thick/rolled at point where they cross.



Two separate throw strings; One horizontal across upper third of the head; one inverted "U" in upper two-thirds of head.

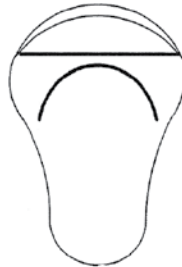

Diagram 15 - Shooting/Throw strings

Appendix F

Measurement Conversions

Metric Conversions

$2.54 \text{ cm} = 1 \text{ in.}$

$3.2 \text{ cm} = 1 \frac{1}{4} \text{ in.}$

$4 \text{ cm} = 1 \frac{1}{2} \text{ in.}$

$4.5 \text{ cm} = 1 \frac{4}{5} \text{ in.}$

$5 \text{ cm} = 2 \text{ in.}$

$6.3 \text{ cm} = 2 \frac{1}{2} \text{ in.}$

$7 \text{ cm} = 2 \frac{3}{4} \text{ in.}$

$7.6 \text{ cm} = 3 \text{ in.}$

$10.1 \text{ cm} = 4 \text{ in.}$

$18 \text{ cm} = 7 \text{ in.}$

$20.3 \text{ cm} = 8 \text{ in.}$

$23 \text{ cm} = 9 \text{ in.}$

$25.4 \text{ cm} = 10 \text{ in.}$

$30.5 \text{ cm} = 12 \text{ in.}$

$40 \text{ cm} = 16 \text{ in.}$

$.9 \text{ m} = 35 \frac{1}{2} \text{ in.}$

$1.1 \text{ m} = 43 \frac{1}{4} \text{ in.}$

$1.22 \text{ m} = 48 \text{ in.}$

$1.83 \text{ m} = 72 \text{ in. (2 yds.)}$

$2.6 \text{ m} = 8 \text{ ft. 6 in.}$

$3 \text{ m} = 9 \text{ ft. 10 in.}$

$4 \text{ m} = 13 \text{ ft. 1 in.}$

$8 \text{ m} = 26 \text{ ft. 3 in.}$

$9 \text{ m} = 30 \text{ ft.}$

$12 \text{ m} = 39 \text{ ft. 4 in.}$

$64 \text{ m} = 70 \text{ yds.}$

$82 \text{ m} = 90 \text{ yds.}$

$92 \text{ m} = 100 \text{ yds.}$

$110 \text{ m} = 120 \text{ yds.}$

$142 \text{ g} = 5 \text{ oz.}$

$149 \text{ g} = 5 \frac{1}{4} \text{ oz.}$

$567 \text{ g} = 20 \text{ oz.}$

$773 \text{ g} = 27 \text{ oz.}$

Appendix G

Alternate Official Responsibilities and Duties

The alternate official is considered part of the team of game officials and should be on the field dressed in game attire. He/She shall take a position at/near the official scorer's table and do the following:

1. Oversee the scorers and timers to determine that:
 - a. Both teams' rosters (a separate roster form is acceptable) are in the official scorebook at least 15 minutes before the start of the game. Confirm that jersey numbers in the book match those on the players.
 - b. The clock is started and stopped correctly and appropriately. Correct any mistakes made in this area. Ensure that a radio is available if necessary (i.e., official time is being kept away from table). Ensure that there is a clock at the table to administer timeouts, penalties, etc.
 - c. Records are kept of team and individual warnings and players who have received cards.
 - d. Proper substitution procedures are followed and substitution records are kept.
 - e. The correct score is maintained in the scorebook and on the scoreboard.
2. Replace any field official in the event of an injury to that official.
3. Assume primary responsibility for maintaining bench personnel positioning and decorum. [See Alternate Official Carding Procedure]
4. Determine the validity of a protest brought by a coach and serve with the three field officials in the deliberation process of valid protests.
5. Review protocol with ball retrievers.
6. Serve in any other capacity that would contribute to maintaining control of the game and efficiency of the scorer's and timer's table.
7. Assist field officials in weather-delay procedures. The alternate official is responsible for noting field position of players during suspension of play due to dangerous weather conditions.
8. Assist with identifying the appropriate times to call television timeouts. The calling of television timeouts will be administered by a "red-cap", who will be located at the scorer's table with the alternate official. Timeouts may be called during the following "natural breaks" in the game:
 - a. Following a goal;

- b. If a team has called a possession timeout;
 - c. During stoppage of play when the ball has gone out of bounds;
 - d. Anytime play has been stopped to set up a free position, except that no television timeout will be allowed if a team has been awarded an 8m free position.
9. Indicate to the timer to stop the clock and indicate to the nearest on-field official that a team has requested a possession timeout.
 10. Call timeout, indicate that all players must drop their crosses and communicate to the nearest field official that a stick check has been requested by the coach.

Alternate Official Carding Procedure

When necessary, the alternate official may issue a yellow or red card for misconduct by a player, coach or any officially designated member of a team's travel party who is in the bench area. When the misconduct occurs, the alternate official will call timeout, approach the head coach, and issue a yellow or red card. The alternate official will inform the nearest on field official that a card was issued to the head coach, and that field official will convey this information to the other on field officials. There will be a change of possession on the field if the offending team is in possession of the ball. The head coach must designate a player on the field who will enter the penalty area and serve a two-minute releasable penalty (yellow card) or two-minute nonreleasable penalty (red card). If a red card has been issued, play will not resume until the head coach leaves the playing area.

Appendix H

Concussions

A concussion is a brain injury that may be caused by a blow to the head, face, neck or elsewhere on the body with an “impulsive” force transmitted to the head. Concussions can occur without loss of consciousness or other obvious signs. A repeat concussion that occurs before the brain recovers from the previous one (hours, days or weeks) can slow recovery or increase the likelihood of having long-term problems. In rare cases, repeat concussions can result in brain swelling, permanent brain damage, and even death.

Recognize and Refer: To help recognize a concussion, watch for the following two events among your student-athletes during both games and practices:

1. A forceful blow to the head or body that results in rapid movement of the head.

-AND-

2. Any change in the student-athlete’s behavior, thinking, or physical functioning (see signs and symptoms).

SIGNS AND SYMPTOMS

Signs Observed by Coaching Staff

- Appears dazed or stunned.
- Is unsure of score or opponent.
- Moves clumsily.
- Answers questions slowly.
- Loses consciousness (even briefly).
- Shows behavior or personality changes.
- Can’t recall events before hit or fall.
- Can’t recall events after hit or fall.

Symptoms Reported by Student-Athlete

- Headache or “pressure” in head.
- Nausea or vomiting.
- Balance problems or dizziness.
- Double or blurry vision.
- Sensitivity to light.
- Sensitivity to noise.
- Feeling sluggish, hazy, foggy or groggy.
- Concentration or memory problems.
- Confusion.
- Does not “feel right.”

An athlete who exhibits signs, symptoms, or behaviors consistent with a concussion, either at rest or during exertion, should be **removed immediately from practice or competition** and should not return to play until cleared by an appropriate health care professional.

IF A CONCUSSION IS SUSPECTED:

1. **Remove the student-athlete from play.** Look for the signs and symptoms of concussion if your student-athlete has experienced a blow to the head. Do not allow the student-athlete to just “shake it off.” Each individual athlete will respond to concussions differently.
2. **Ensure that the student-athlete is evaluated right away by an appropriate health care professional.** Do not try to judge the severity of the injury yourself. Immediately refer the student-athlete to the appropriate athletics

medical staff, such as a certified athletic trainer, team physician or health care professional experienced in concussion evaluation and management.

3. **Allow the student-athlete to return to play only with permission from a health care professional with experience in evaluating for concussion.** Allow athletics medical staff to rely on their clinical skills and protocols in evaluating the athlete to establish the appropriate time to return to play. A return-to-action progression should occur in an individualized, step-wise fashion with gradual increments in physical exertion and risk of contact. Follow your institution's physician supervised concussion management protocol.
4. **Develop a game plan.** Student-athletes should not return to play until cleared by the appropriate athletics medical staff. In fact, as concussion management continues to evolve with new science, the care is becoming more conservative and return-to-play time frames are getting longer. Coaches should have a game plan that accounts for student-athletes to be out for at least the remainder of the day.

For further details please refer to the "NCAA Sports Medicine Handbook Guideline on Concussions" or online at www.NCAA.org/health-safety and www.CDC.gov/Concussion.



Index to Rules

Term (<i>Rule–Section</i>)	Page	Term (<i>Rule–Section</i>)	Page
B			
Baiting, taunting (6–8).....	41	major (6–1).....	36
Ball		minor (6–2).....	38
described (2–5).....	16	misconduct (6–8).....	41
lodged in clothing, crosse (5–26).....	34	offsetting (7–1).....	42
touching with hands (6–2-d).....	39	offside (6–7).....	40
Benches – team (1–10).....	10	Free position (7–1).....	42
C			
Captains (3–6).....	19	Free position, indirect (7–11).....	44
speaking (3–1).....	19	(8).....	52
Carding/score verification form (3–11-k).....	21	Free space to goal (8).....	51
Cards		G	
delay of game (7–26).....	46	Game	
mandatory (6–1).....	36	forfeit (4–6).....	24
misconduct (7–27).....	47	length of (4–1).....	23
Center circle (1–6).....	10	start/restart of (5–1).....	26
Checking (8).....	50	suspended/interrupted (4–5).....	24
Clear (8).....	50	Game administrator (3–5).....	19
Coaches		Goal (1–14).....	13
duties of (3–3, 4).....	19	nets (1–14).....	14
equipment certification (3–2).....	19	not scored (4–9).....	25
Coaching area (1–12).....	10	scored (4–8).....	24
Coin toss (3–6).....	19	scored with illegal crosse (5–27-c).....	34
Critical scoring area (8).....	50	Goal circle	
Crosse, field (2–1).....	15	dimensions (1–15).....	14
legal (2–2).....	15	fouls related to (6–3-6).....	40
request to be checked (5–27).....	34	returning the ball to (5–18).....	30
throwing of (6–2-g).....	39	Goalkeeper	
Crosse, goalkeeper (2–3).....	15	crosse (2–3).....	15
legal (2–3).....	15	duties of (5–16).....	30
D			
Delay of game (6–2-r).....	39	equipment (2–6).....	16
Deputy (5–17).....	30	grounded (8).....	52
Draw		helmet requirements (2–6).....	16
description of (5–2).....	26	outside the goal circle (5–19).....	30
foul (6–2-i).....	39	privileges of (5–15).....	29
illegal (5–3).....	27	H	
positioning of players (5–1).....	26	Halftime (4–1).....	23
E			
8m arc (1–7, 8).....	10	I	
Ejection		Injured player (5–25).....	34
during game (7–30).....	48	Interruption of game (5–24).....	33
postgame (7–34).....	49	J	
Equipment		Jewelry (2–10).....	17
inspection of (5–27).....	34	L	
personal (2–10).....	17	Lines – width, color (1–4).....	9
Eye protection (2–9).....	17	Lineup (3–11).....	20
F			
Field		M	
diagram (1).....	12, 13	Misconduct (6–8).....	41
dimensions (1–1).....	9	Mouthpiece (2–8).....	17
not meeting specifications (1–2).....	9	N	
Flagrant foul (6–8).....	41	Numbers on shirts (2–13).....	18
(7–30).....	48	O	
Forfeited game (4–6).....	24	Obstruction, free space to goal (6–1-o).....	37
Fouls		(7–19).....	45
goal circle (6–3-6).....	40	Offside (5–6).....	27
		by attack (7–6).....	43
		by defense (7–7-9).....	43

Term (Rule–Section)	Page
Out of bounds	
ball out (5–7)	27
draw (5–14)	29
player out of bounds (5–8)	28
player with possession (5–9)	28
resuming play (5–11)	28
shot, deflected shot (5–12, 13)	28–29
Overtime (4–7)	24
P	
Penalty administration	
general (7–1)	42
goal circle (7–10)	44
major fouls (7–4)	42
minor fouls (7–5)	43
offside (7–6, 9)	43
Played (8)	53
Play – start/restart of (5–4)	27
R	
Restraining line (1–5)	9
S	
Scorer, official – duties of (3–10, 11)	20
Scorer/timer's table (1–11)	10
Scoring play (7–20)	45
Slow whistle	
additional fouls during (7–23)	46
description (7–17)	45
enforcement (7–21)	46
in effect (7–18)	45
Spectator area (1–13)	11
Stand (5–5)	27
Stick check (5–27)	35
mandatory (5–27)	35
Substitution	
after a card (5–22-d)	32
after goals (5–22-b)	32
area (1–9)	10
during play (5–22-a)	32
illegal (5–23)	33
injury (5–22-c)	32
T	
Team – defined (3–1)	19
Ten-goal rule (4–3)	23
Throw (5–20)	31
Timeouts	
mandatory (4–1)	23
team (4–4)	23
12m fan (1–7)	10
Timer, official – duties of (3–12, 13)	21
U	
Umpires	
duties before the game (3–8)	20
number of (3–7)	20
other responsibilities (3–9)	20
Undergarments, visible (2–15, 16)	18
Uniforms	
goalkeeper (2–12)	18
kilt/shorts (2–12)	18
numbers (2–13)	18
shirt (2–14)	18
shoes (2–11)	18



Sportsmanship is a core value of the NCAA. The NCAA Committee on Sportsmanship and Ethical Conduct has identified **respect** and **integrity** as two critical elements of sportsmanship and launched an awareness and action campaign at the NCAA Convention in January 2009.

Athletics administrators may download materials and view best practices at the website below: **www.NCAA.org**, then click on **"Student-Athlete Programs,"** then **"Sportsmanship"** and select the **"Resources/Best Practices"** tab.



RESPECT.

It's the name of the game.

The NCAA salutes the more than
430,000 student-athletes
participating in **23 sports** at
more than **1,200** member institutions

